

Revision History			
REV	DESCRIPTION (ECO)	DATE	APPROVED
V	ADD Q.C. ECN 4357	2/22/10	AK
W	UPDATE TITLE TO READ TUBING CLAMP ECN 5018	11/18/11	AK

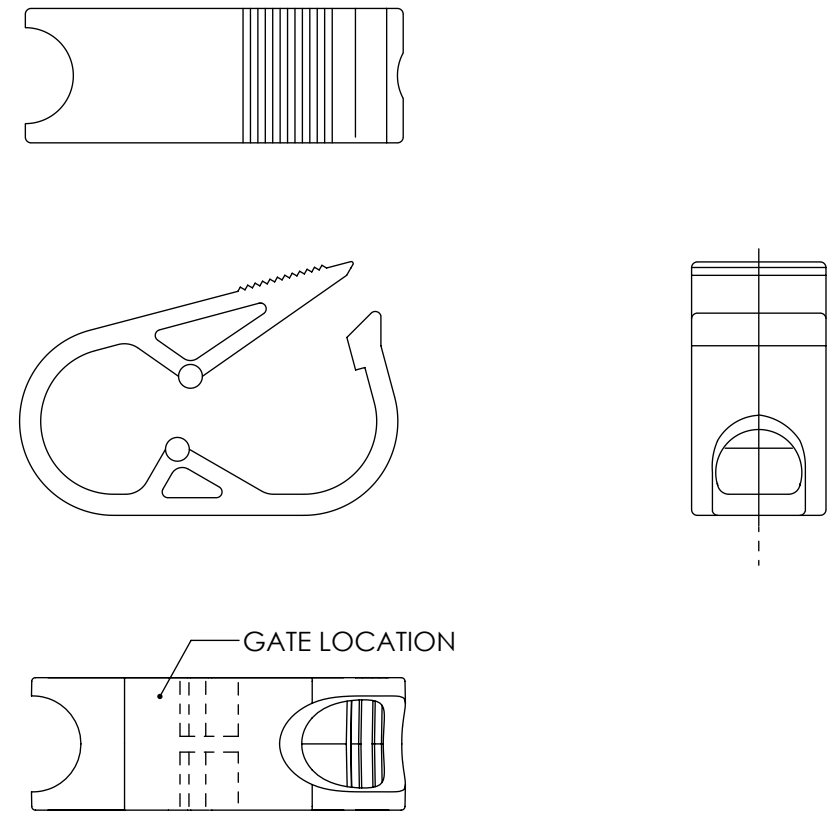
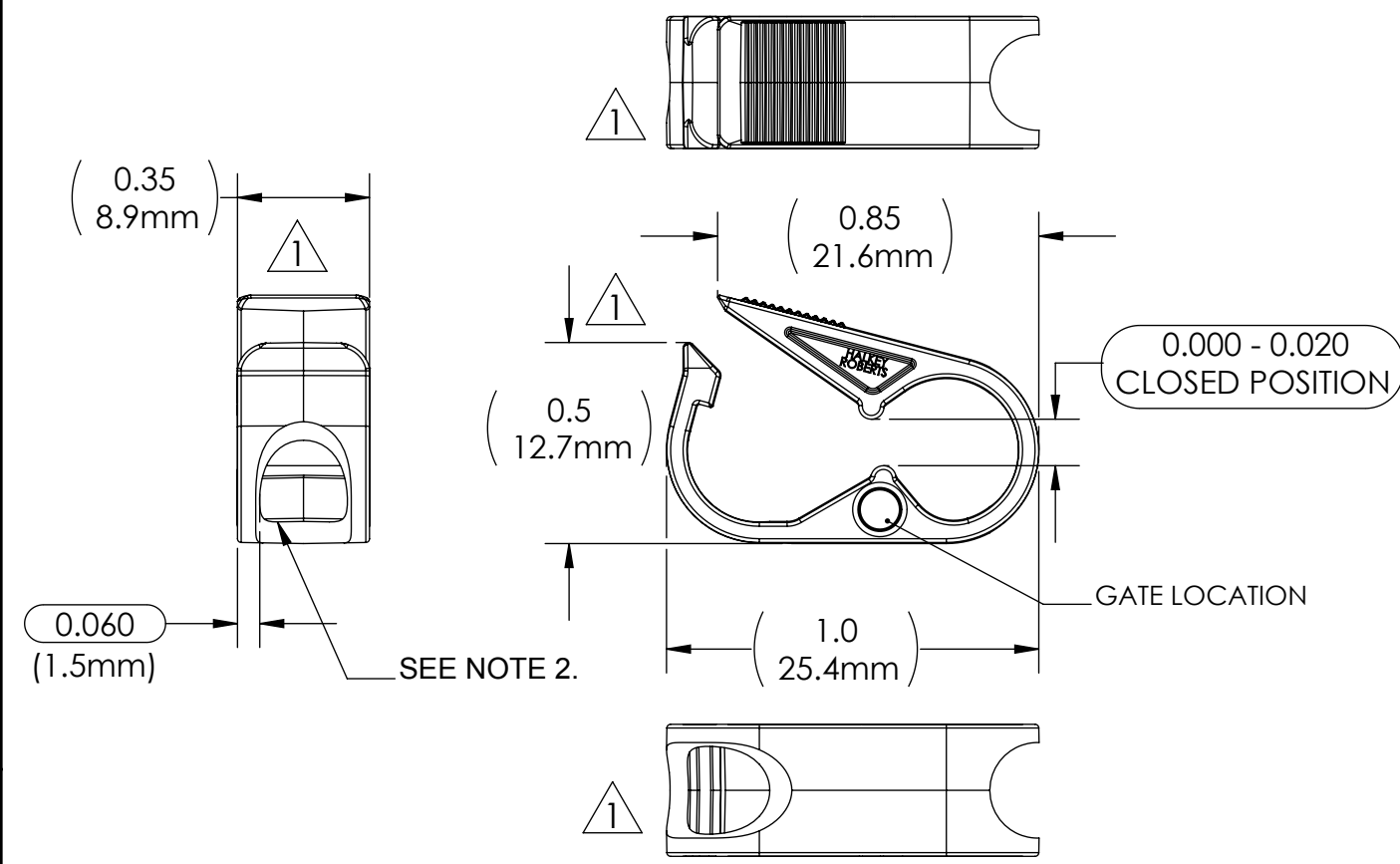

NOTES:

1. VIEWS SHOWN OF ALTERNATE GATE LOCATION, AND RADIUS CONFIGURATION.
2. MAX TUBING DIAMETER (0.25").
3. CRITICAL DIMENSION ARE CIRCLED AND SUBJECT TO INSPECTION.
4. DIMENSIONS IN PARENTHESES ARE FOR REFERENCE ONLY.
5. ALL DIMENSIONS ARE IN INCHES WITH NOMINAL DIMENSIONS IN MILLIMETERS SHOWN BELOW.
6. HR TUBING CLAMPS ARE SINGLE PATIENT USE MEDICAL COMPONENTS INTENDED TO BE INCLUDED AS PART OF THE FINISHED DEVICE, I.E. IV ADMINISTRATION SETS. HR TUBING CLAMPS ARE MANUFACTURED TO HR SPECIFICATIONS, SOLD BULK, NON-STERILE TO OEMS. BECAUSE THE CONFIGURATIONS OF IV TUBING VARY DRAMATICALLY, HR CANNOT MAKE ANY PARTICULAR CLAIMS. CUSTOMERS MUST VALIDATE CLAMPS FOR THEIR INTENDED USE, ENSURING THAT THE CLAMPS EFFECTIVELY OCCLUDE THE INHERENT VARIATION OF THE PARTICULAR TUBING EMPLOYED BY THE CUSTOMER AGAINST THE CLOSED GAP RANGE PROVIDED ON HR'S SPECIFICATIONS. OEM MANUFACTURING PROCESSES (SUCH AS ASSEMBLY PROCESSES, PACKAGING AND STERILIZATION) CAN SIGNIFICANTLY ALTER THE CLAMPS' FUNCTIONALITY; THEREFORE, HR CANNOT GUARANTEE THE PERFORMANCE OF THE FINAL CONFIGURATION.

- SUFFIX OPTIONS**
- | | | |
|--------------|-------------------|--------|
| C340TCS | NO SUFFIX - WHITE | CELCON |
| C340TCSB | B - BLUE | |
| C340TCSR | R - RED | |
| C340TCSY | Y - YELLOW | |
| C340TCSBK | BK- BLACK | |
| C340TCS CR | CR- CREAM | |
| C340TCSYL | YL- YELLOW | |
| C340TCSPL | PL - PURPLE | |
| C340TCSBN | BN-BROWN | |
| C340TCS2002W | W - WHITE | ABS |
| C340TCS248B | 248B - BLUE | ABS |
| C340TCS248R | 248R - RED | ABS |

QUALITY CRITERIA

O.D. FLASH 0.015 MAX. (0.4MM)
GATE VESTIGE 0.01 MAX. (0.3MM)
EMBEDDED PARTICLES, BUBBLES, SPOTS, STAINS: 0.3mm ² MAX. NO MORE THAN 5 PER PART.

DRAWN BY M.S. DATE - APPROVED BY J.W. DATE 07/20/88		
MATERIAL SEE NOTE FINISH		
TITLE TUBING CLAMP SMALL		SIZE B SCALE 2:1
DRAWING NO. C340TCSX REV W		
DO NOT SCALE DRAWING		SHEET 1 OF 2

MOLDED PARTS:
 GATES, PARTING LINES, AND FLASH PER QUALITY CRITERIA
PROPRIETARY AND CONFIDENTIAL
 THE INFORMATION CONTAINED IN THIS DRAWING IS THE SOLE PROPERTY OF HALKEY-ROBERTS CORPORATION, ST. PETERSBURG, FL. ANY REPRODUCTION IN PART OR AS A WHOLE WITHOUT THE WRITTEN PERMISSION OF HALKEY-ROBERTS CORPORATION IS PROHIBITED.

UNLESS OTHERWISE SPECIFIED:
 DIMENSIONS ARE IN INCHES
 TOLERANCES:
 ANGULAR: ± 1°
 TWO PLACE DECIMAL ± .01
 THREE PLACE DECIMAL ± .005

THIRD ANGLE PROJECTION