

### PRODUCT SPEC

Item Number	323-100	Size	64oz
Product Description	64oz Dual Chamber Dosing Bottle	Overflow Volume	81oz
Material	HDPE	Packaging Type	Tray Pack
PCR	0%	Unit Qty	672
Color	Natural	Truckload Qty	20,160
Gram Weight	145		

### PRODUCT DIMENSIONS

<i>Body</i>		
	Width	3.212+-0.060
	Depth	6.054+-0.090
	Height	11.000+-0.080
<i>Finish</i>		
	Neck Finish	38mm
	T	1.464+-0.012
	E	1.370+-0.012
	H	0.523+-0.015
	S	0.046+-0.015

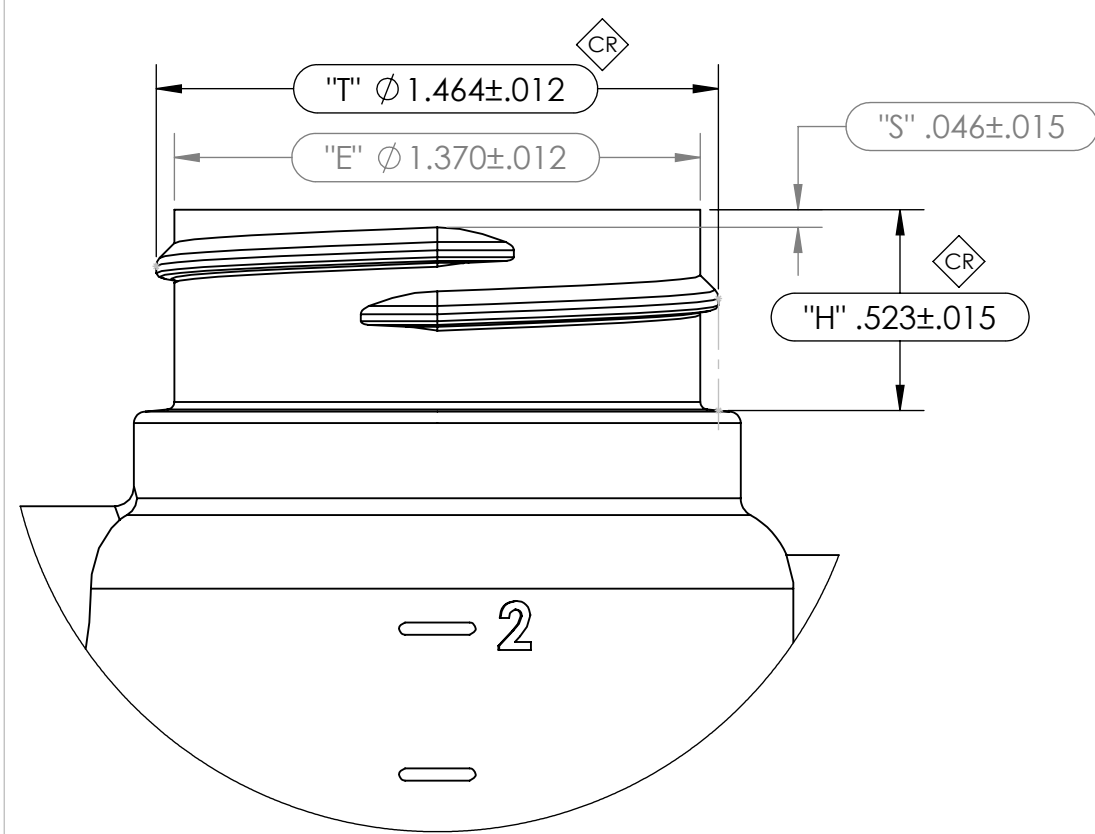

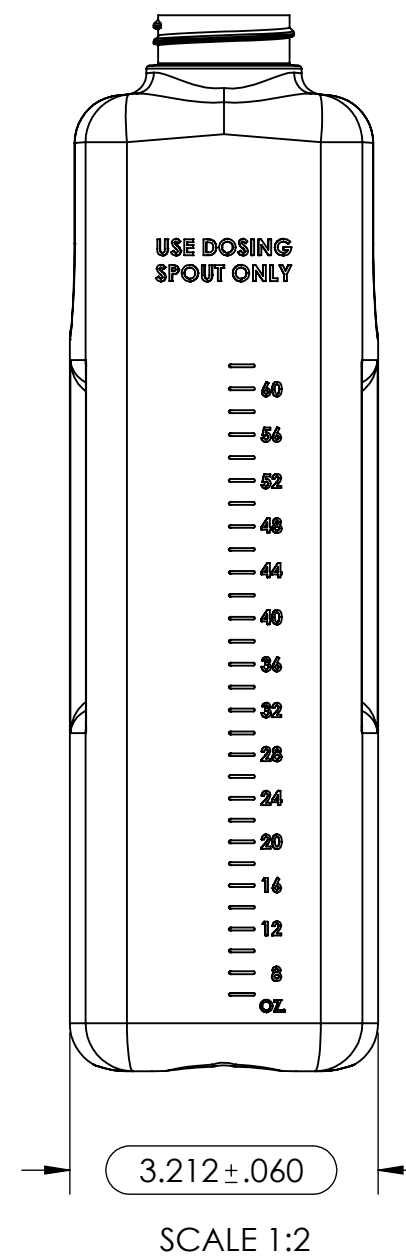
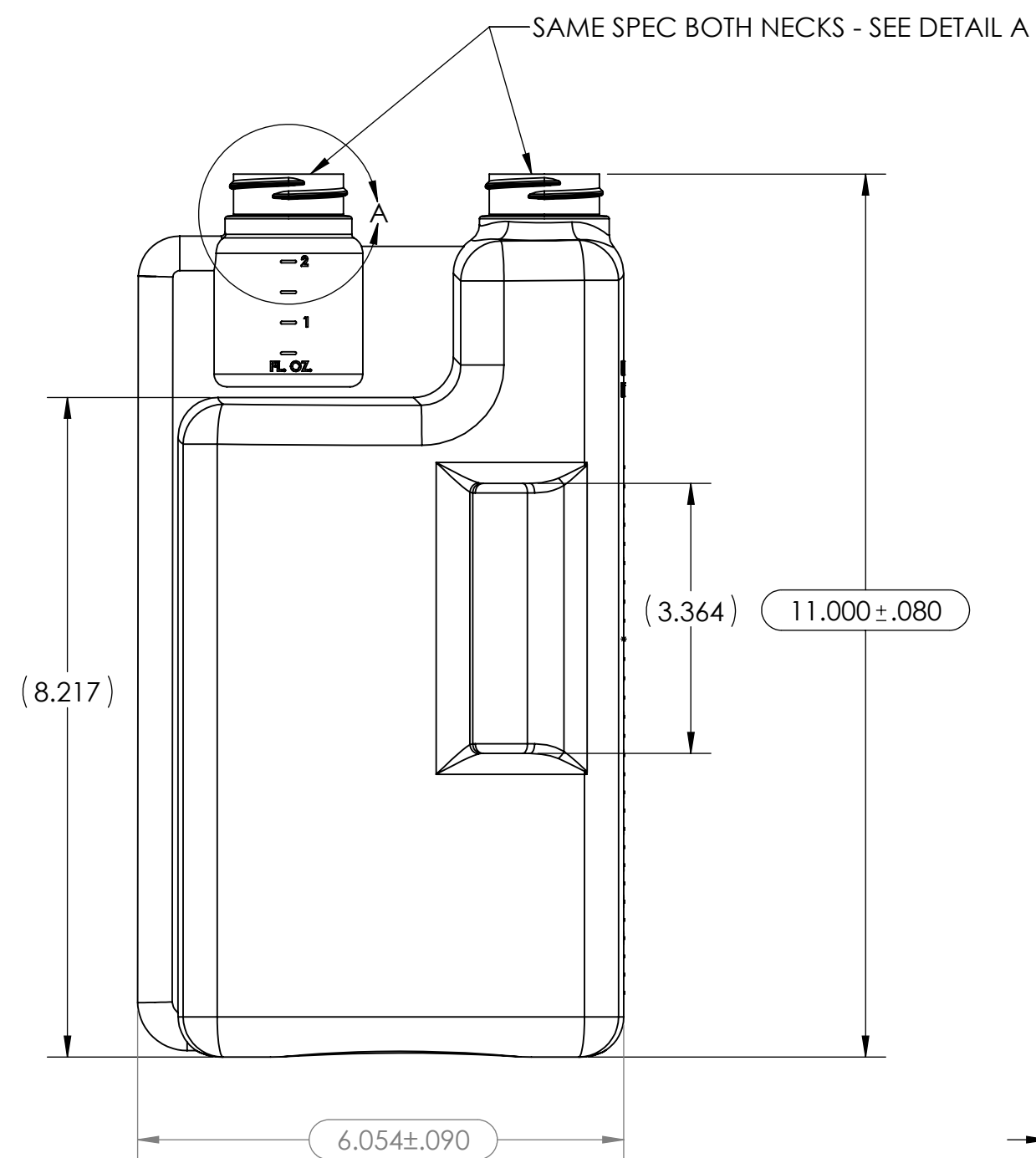
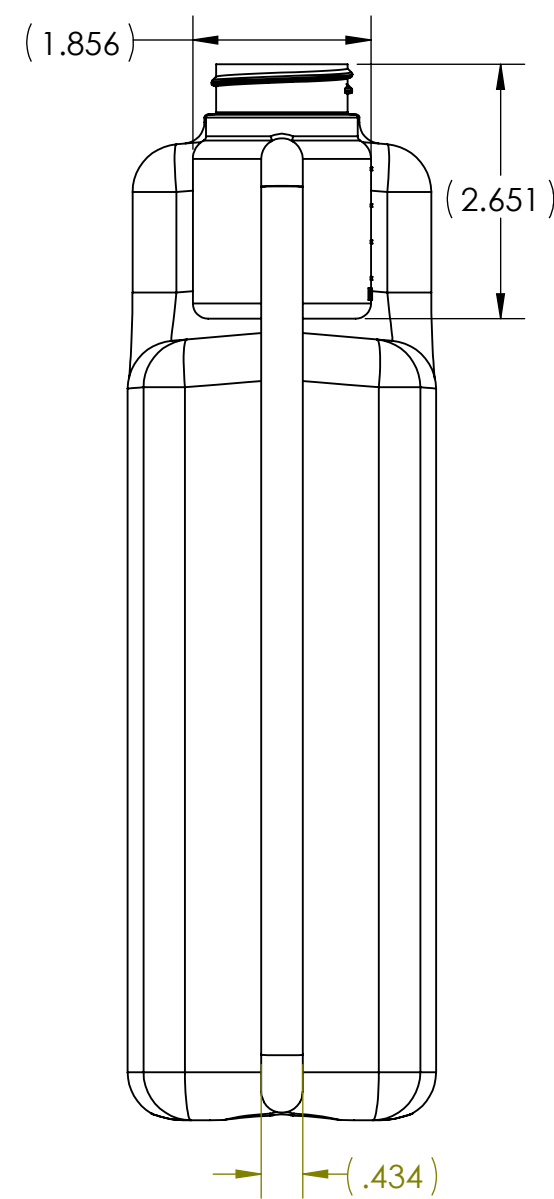
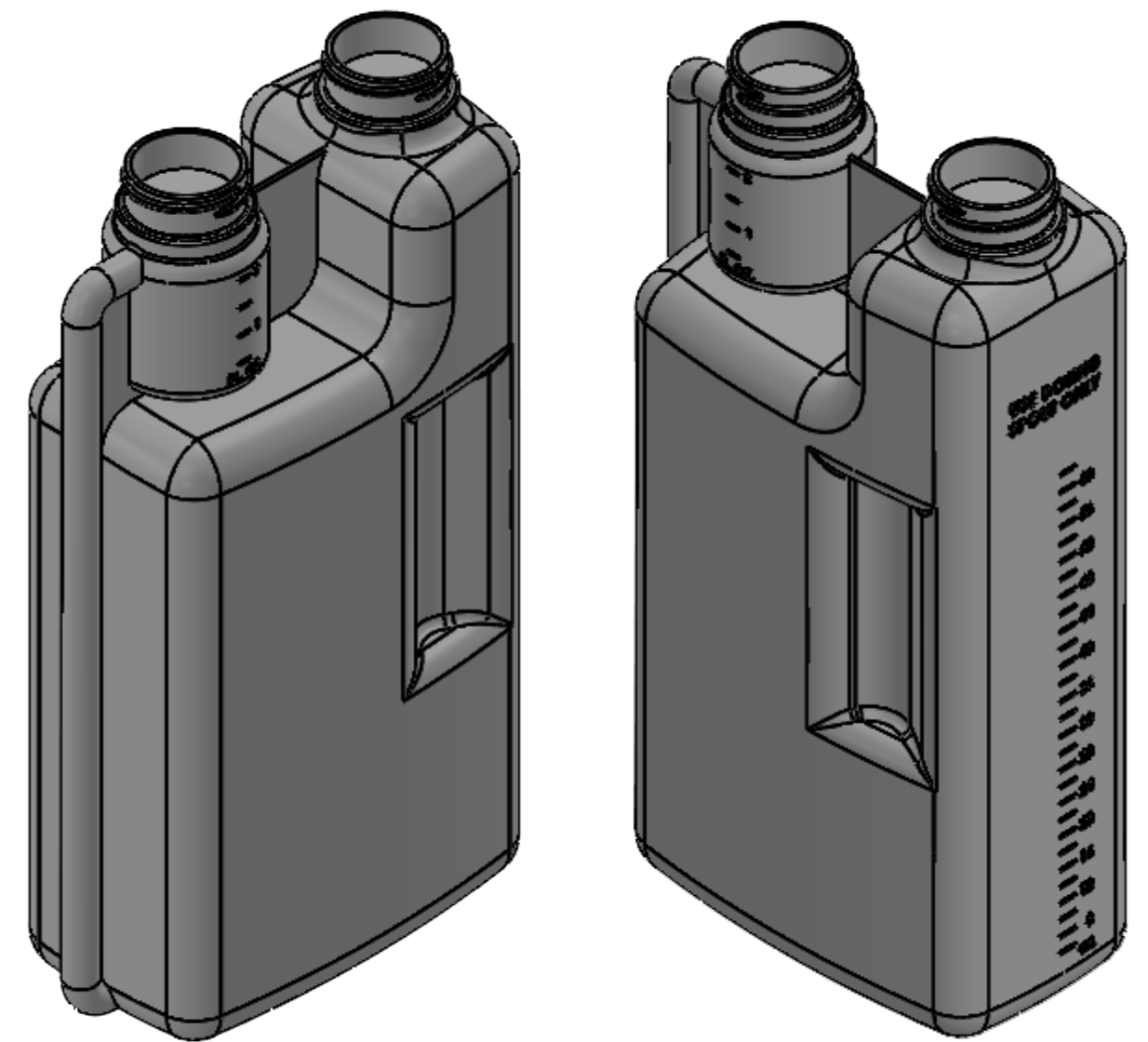
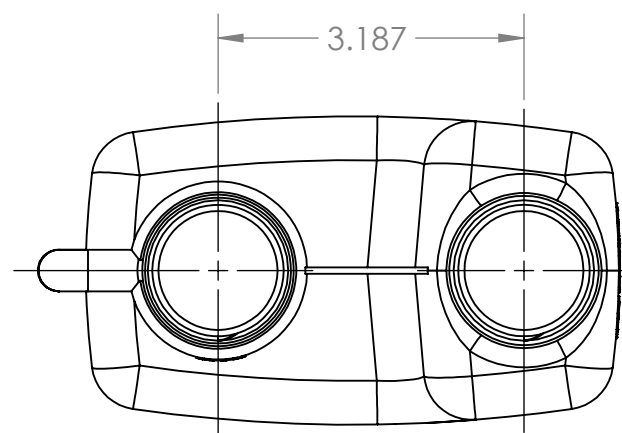

DETAIL A  
SCALE 2:1

38MM NECK FINISH  
6.T.P.I  
1 FULL THREAD TURN  
TYP. FOR BOTH  
NECKS

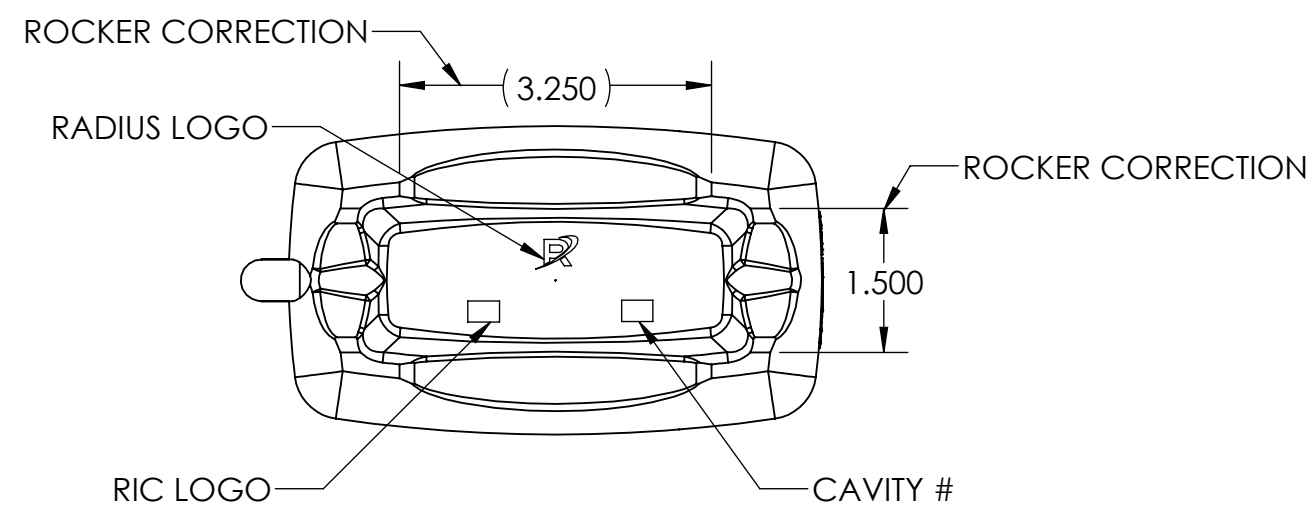

1. DIMENSIONS OR NOTES MARKED WITH A DENOTE CRITICAL CHARACTERISTICS TO BE MONITORED DURING PRODUCTION.
2. DIMENSIONS OR NOTES MARKED WITH A DENOTE CHARACTERISTICS TO BE MONITORED DURING PRODUCTION QUALIFICATION ONLY.
3. ALL DIAMETER DIMENSIONS MARKED WITH OR SHALL BE DETERMINED BY AVERAGING THE MEASUREMENTS AT PARTING LINE AND 90 DEGREES FROM PARTING LINE
4. REFERENCE ONLY DIMENSIONS CONTAINED IN ( ).
5. MINIMUM CONTAINER WALL THICKNESS .
6. CONTAINER TOP LOAD REQUIREMENT TO BE LBS. MINIMUM AT 1/4" DEFLECTION.
7. MATERIAL HDPE .
8. TARGET WEIGHT 145.0 GRAMS.
9. OVERFLOW CAPACITY 81.0 FL. OZ. CAD ESTIMATED
10. MEASUREMENTS TAKEN 24 HOURS AFTER MOLDING.



				 <b>RADIUS PACKAGING</b> <b>NEW BERLIN, WISCONSIN</b>			
				TITLE: 64oz DUAL CHAMBER DOSING			
				DESCRIPTION: PRODUCT DRAWING			
REV	DATE	CHECKED BY	DATE	BY	DATE	<small>PROPRIETARY AND CONFIDENTIAL</small> <small>THE INFORMATION CONTAINED IN THIS DRAWING IS THE SOLE PROPERTY OF RADIUS PACKAGING. ANY REPRODUCTION IN PART OR AS A WHOLE WITHOUT THE WRITTEN PERMISSION OF RADIUS PACKAGING IS PROHIBITED.</small>	
MS	2/9/2014	ZMF	3/11/24			DRWG. NO. 323PD	
SIZE <b>C</b>		SCALE 1:1		SHEET 1 OF 1		REV.	

(TOP VIEW)

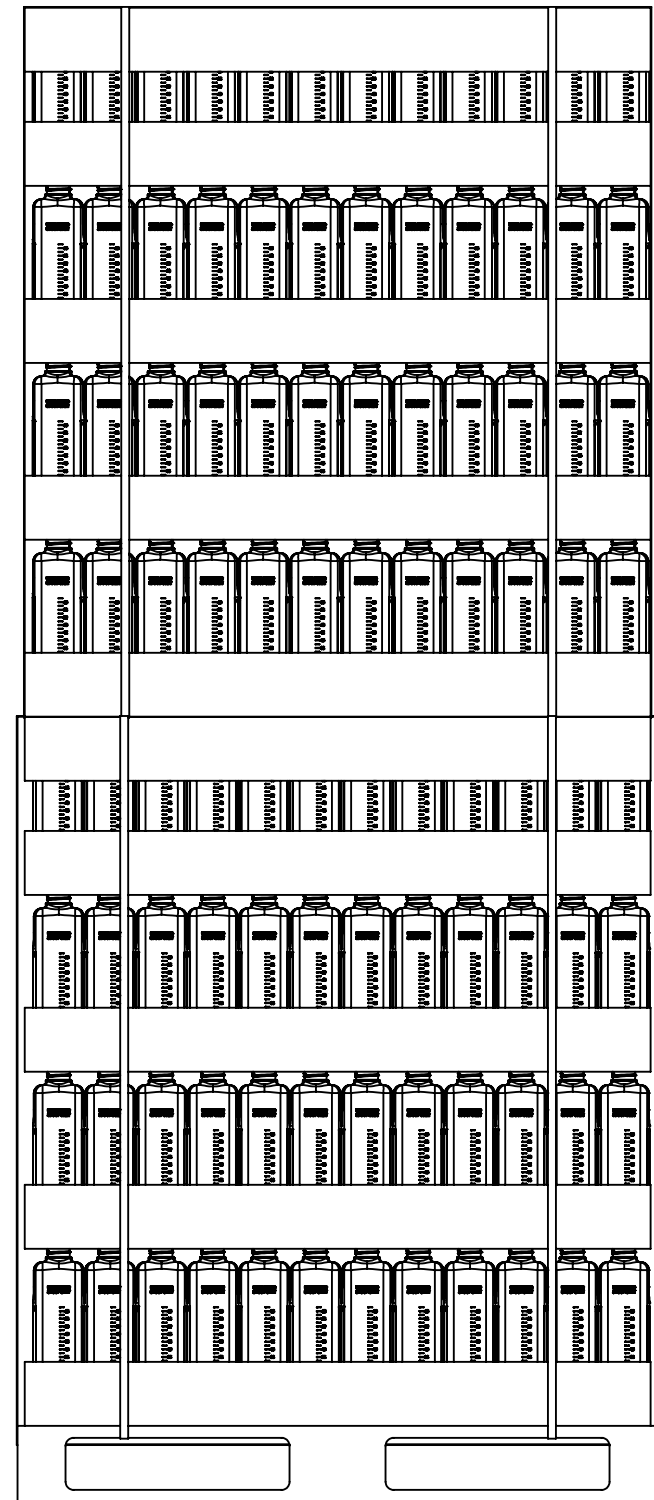
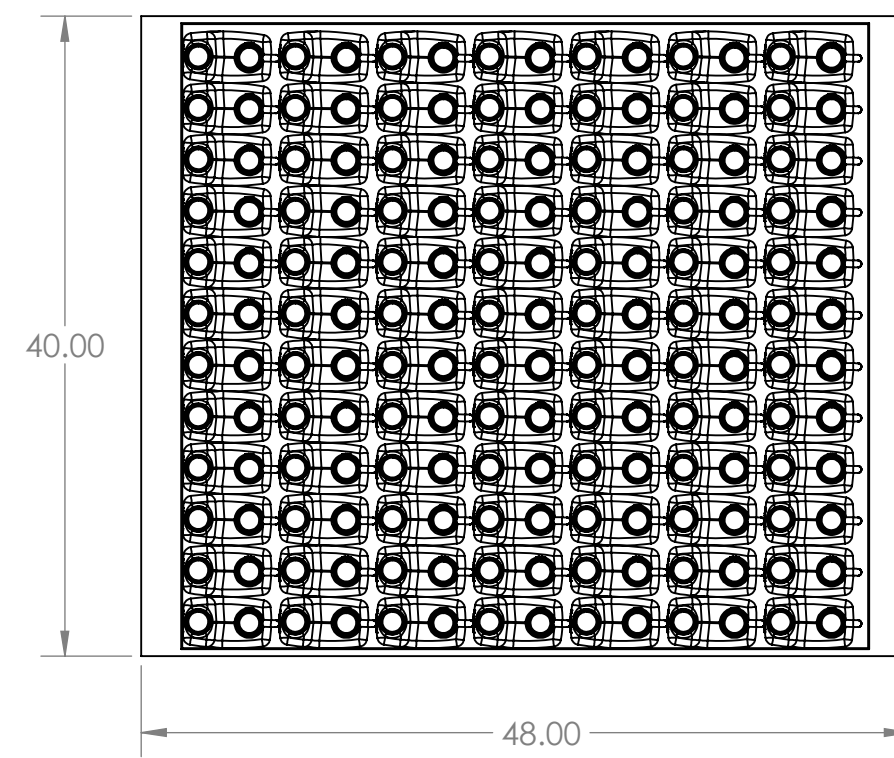

(SIDE VIEW)

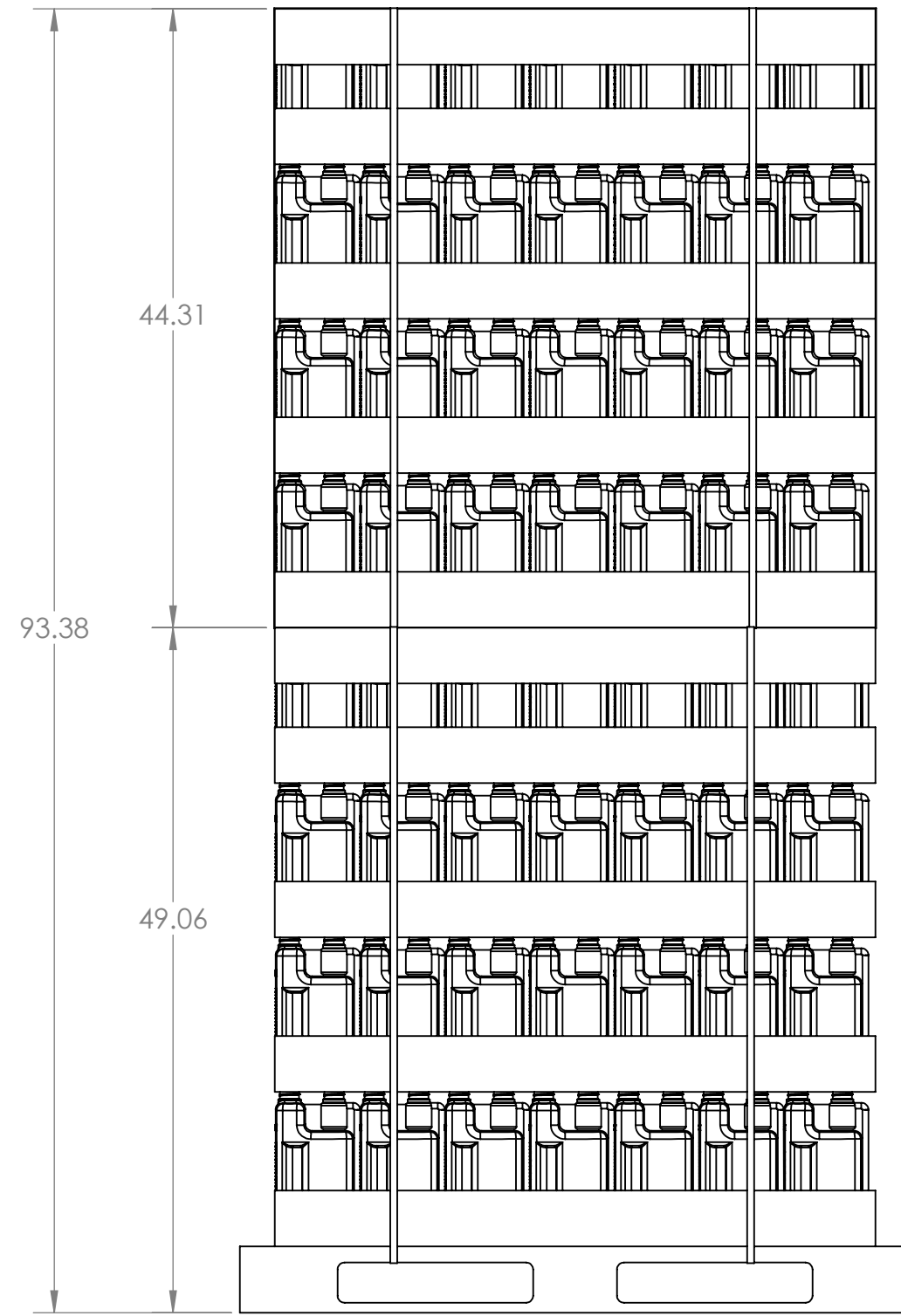

PALLET: MP40X48WDA (40" x 48" WOOD - QTY 1)  
 TRAY: C39434BT - QTY 10

EACH UNIT IS INDIVIDUALLY BANDED & STRETCH WRAPPED  
 (2 STRAPS IN EACH DIRECTION)  
 \*STRAP BOTTOM UNIT TO PALLET

CAPACITY:  
 84 BOTTLES/LAYERS  
 BOTTOM UNIT: 4 LAYERS  
 TOP UNIT: 4 LAYERS  
 84\* 8 LAYERS/SKID  
 672 BOTTLES/SKID

CAPACITY PER TRAILER:  
 672 BOTTLES/SKID  
 30 SKIDS/TRAILER  
 20,160 BOTTLES/TRAILER

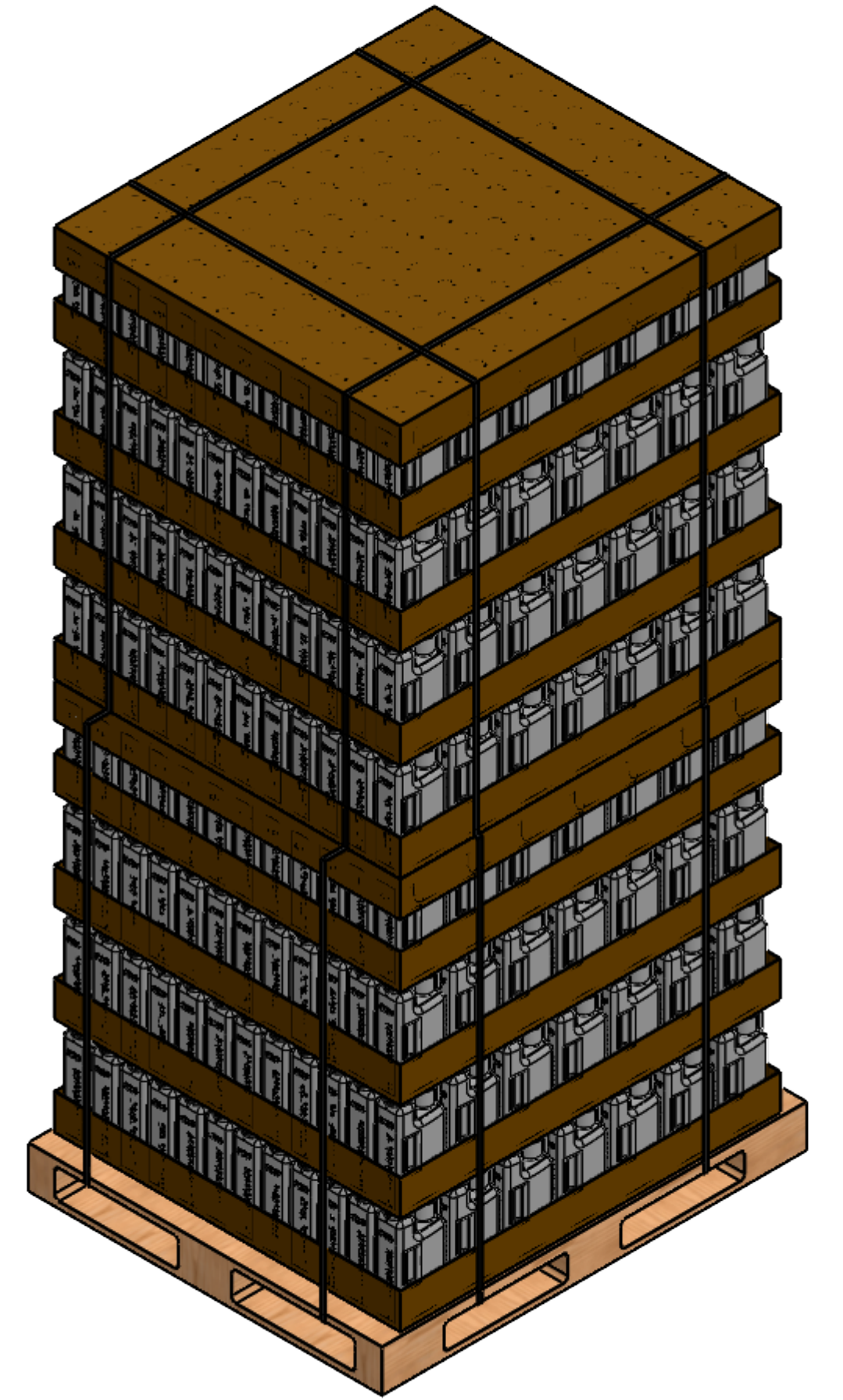

CUSTOMER SIGNATURE: \_\_\_\_\_  
 DATE: \_\_\_\_\_



TITLE: 64oz DUAL CHAMBER DOSING

DESCRIPTION: PACKAGING DRAWING

DRWG. NO. 323PKG

SIZE: D SCALE: 1:1 SHEET 1 OF 1 REV.

REV	DESCRIPTION	BY	DATE
DRAWN BY	DATE	CHECKED BY	DATE
MS	4/24/2024		

**PROPRIETARY AND CONFIDENTIAL**  
 THE INFORMATION CONTAINED IN THIS DRAWING IS THE SOLE PROPERTY OF RADIUS PACKAGING. ANY REPRODUCTION IN PART OR AS A WHOLE WITHOUT THE WRITTEN PERMISSION OF RADIUS PACKAGING IS PROHIBITED.