

Copyright. All information furnished within this document, electronic file or design correspondence is the property of Den Hartog Industries, Inc. and shall not be used, disclosed to others or copied without the expressed written consent of Den Hartog Industries, Inc.

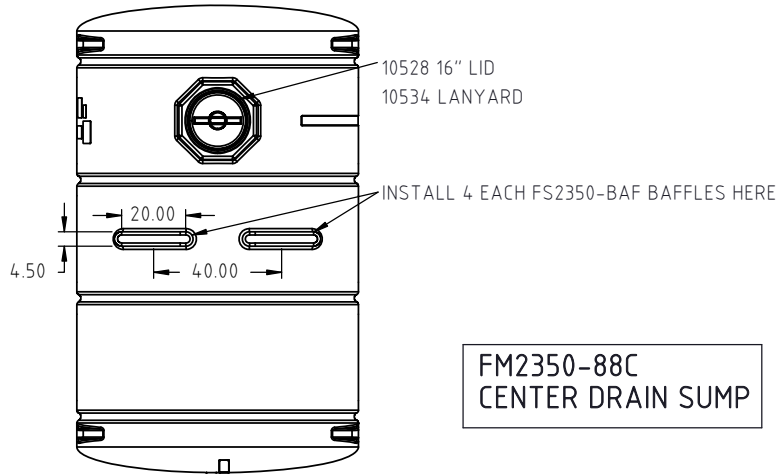

FM2350-88C  
CENTER DRAIN SUMP

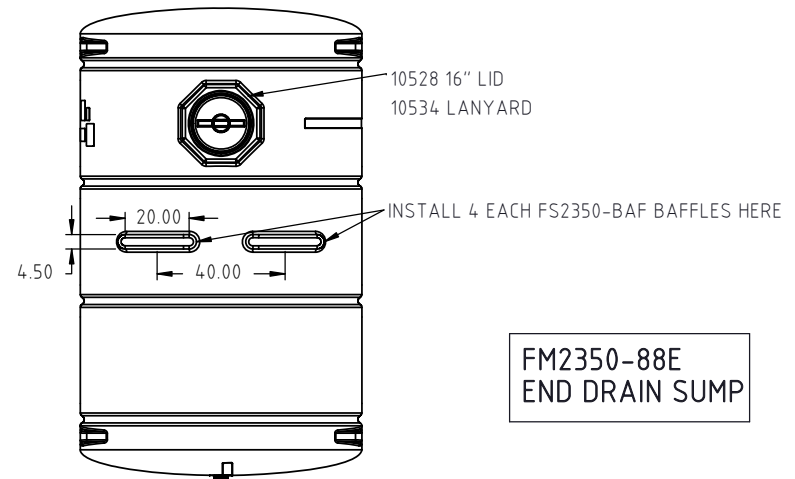

FM2350-88E  
END DRAIN SUMP

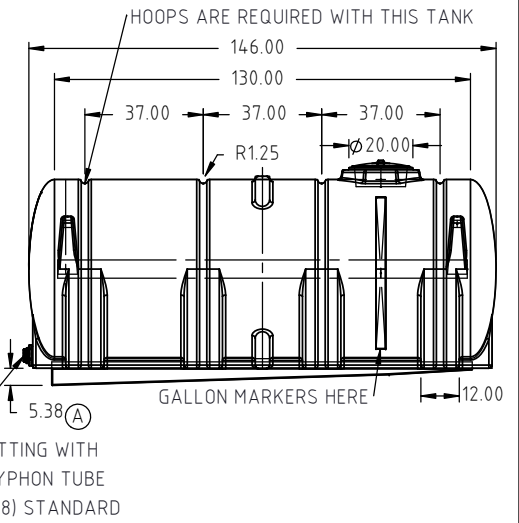
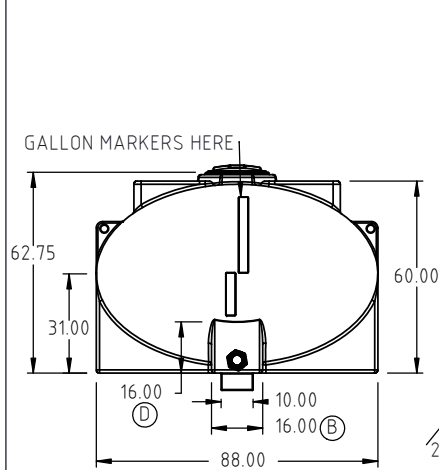
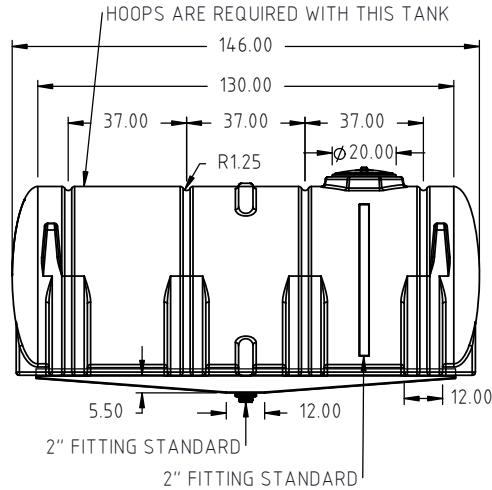
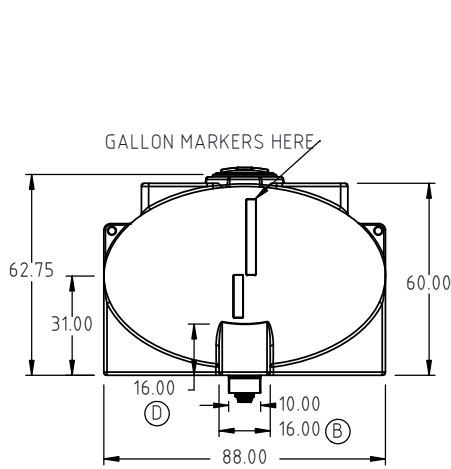

D	16.00" CORRECTED FROM 9.42"	ADH 9/6/19	3839
C	1/27/12 WAS INCORRECTLY SHOWN AS 12/27/12	ADH 11/8/12	2468
B	16.00" WAS 12.00" (C)	ADH 1/27/12	2358
A	SYPHON TUBE NOTE UPDATED	ADH 5/9/11	2212
REV	DESCRIPTION	BY / DATE	CCN

DRAWN / DATE	MATERIAL
ADH 4/13/10	10538 NATURAL
APPRD. / DATE	
REH 4/19/10	



**Den Hartog**  
INDUSTRIES, INC.

Ace Roto-Mold Injection Molding Blow Molding Sowjoy

4010 HOSPERS DRIVE S. BOX 425, HOSPERS, IOWA 51238-0425

ALL DIMENSIONS ARE IN DECIMAL INCHES TOLERANCES UNLESS OTHERWISE SPECIFIED  
POLYETHYLENE METAL DECIMAL ± .125" FRACTION ± 1/4" ANGLE ± 1°  
±1% @ 68°F

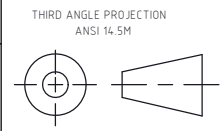

SHOT WEIGHT:	840 LBS.
SHIPPING WEIGHT:	920 LBS.
FINISH:	

NOTES:  
1.) 0.480 NOMINAL WALL  
2.) BLUE, BLACK, WHITE OR YELLOW COLOR

DESCRIPTION	2350 GALLON ELLIPTICAL LEG TANK WITH SUMP	
SCALE	N.S.	PART NO. FM2350-88