

DETAIL A

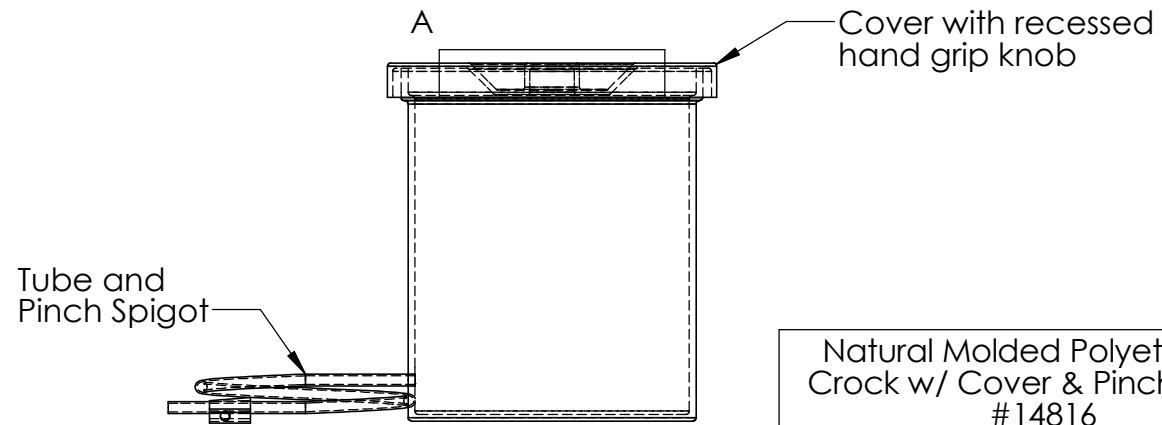

Natural Molded Polyethylene
Crock w/ Cover & Pinch Spigot
#14816

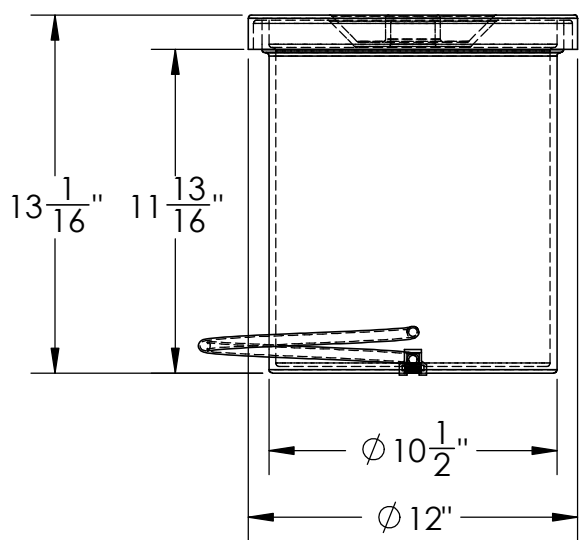
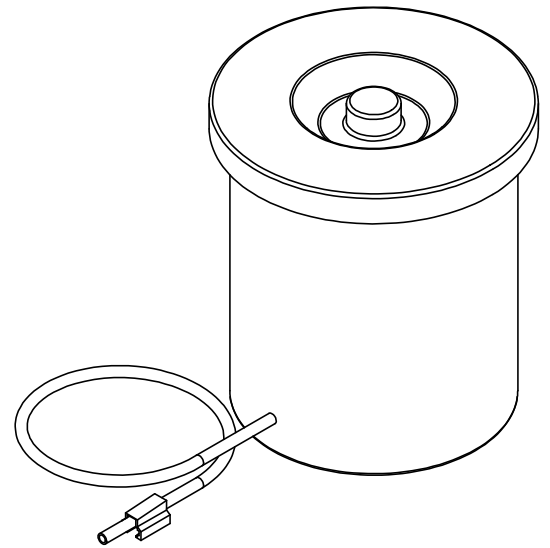

DIMENSIONS ARE IN INCHES TOLERANCE: ± 1/4"		NAME	DATE
MATERIAL LLDPE - FDA resin		DRAWN JMP	06/03/20
CAPACITY 5 US gal.		APPROVED	
GRADUATIONS NO		COMMENTS: Translucent UV Stabilized	
NOMINAL WALL THICKNESS 3/16"			

STOCK NO.	REV
14816	A
DO NOT SCALE DRAWING	WEIGHT: 5 lbs.

PROPRIETARY AND CONFIDENTIAL
THE INFORMATION CONTAINED IN THIS DRAWING IS THE SOLE PROPERTY OF TAMCO. ANY REPRODUCTION IN PART OR AS A WHOLE WITHOUT THE WRITTEN PERMISSION OF TAMCO IS PROHIBITED.

MAX. OPERATING TEMP. 140°F
INTERMITTENT SERVICE TO 160°F
SEE CHEMICAL RESISTANCE CHART FOR COMPATIBILITY