

ITEM NO.	PART NUMBER	DESCRIPTION	QTY.
1	AMMA2	ARM, MINI FV, ADJ, THD	1
2	LVMA2	LEVER ARM, 1/2" MINI VALVE ADJUSTABLE	1
3	DSM	SEAL, MINI VALVE	1
4	PF154-NT	FLOAT, FV, 1.5X4,1/4	1
5	CPM	COTTER PIN, 1/16X1	1
6	CB05	BOLT, 10-32 X 3/4	1
7	WN05	WING NUT, 10-32	1
8	2S2	1/4 HOUSING, MINI VALVE	1

THIS DOCUMENT CONTAINS PROPRIETARY AND CONFIDENTIAL INFORMATION OF CONTROL DEVICES LLC AND MUST BE USED STRICTLY IN ACCORDANCE WITH THE LIMITED PURPOSE FOR WHICH IT WAS SUBMITTED. ANY REPRODUCTION, DISCLOSURE OR USE OF THIS DOCUMENT IS EXPRESSLY PROHIBITED, EXCEPT AS OTHERWISE AGREED IN WRITING.

REVISIONS			
REV	DESCRIPTION	DATE	ECN NO.
A	RELEASE TO PRODUCTION	6/14/18	18-473

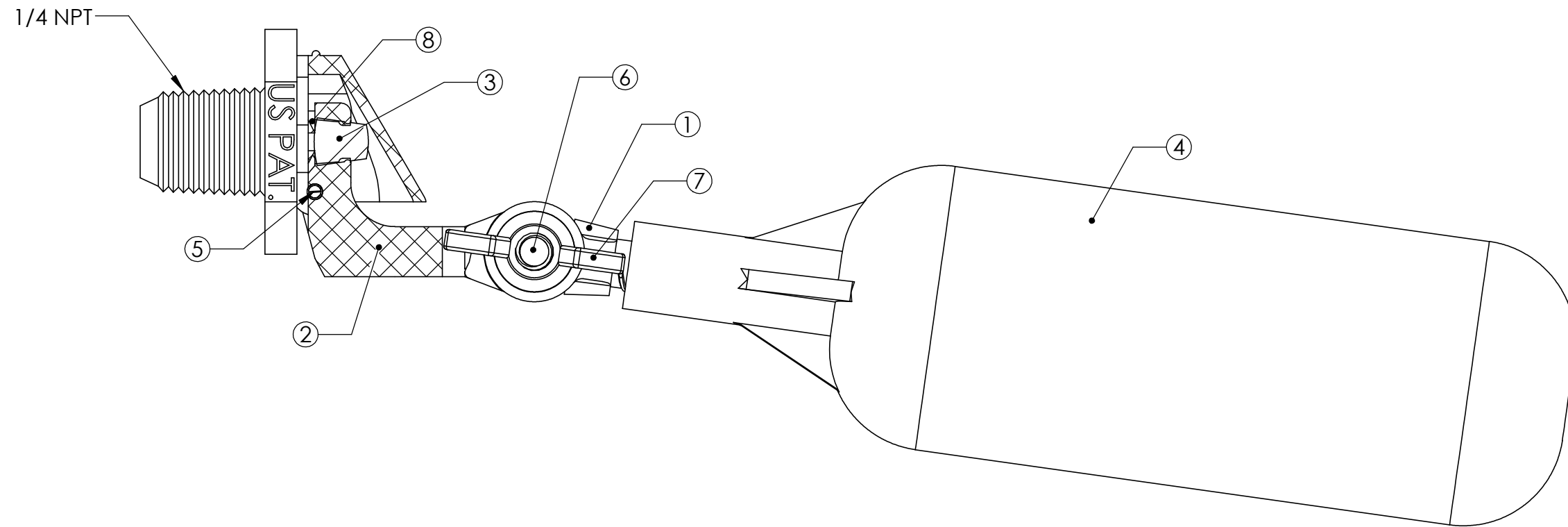
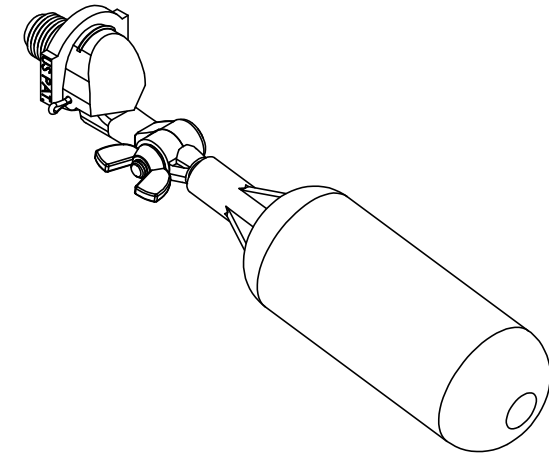

- NOTES:
1. FLOW 1.5 GPM @ 60 PSI
 2. NSF APPROVED
 3. MAX PRESSURE 100 PSI
 4. MAX TEMP 180° F

ITEM NO.	PART OR IDENTIFYING NO.	NOMENCLATURE OR DESCRIPTION	MATERIAL SPECIFICATION	QTY REQD
PARTS LIST				
UNLESS OTHERWISE SPECIFIED DIMENSIONS ARE IN INCHES TOLERANCES ARE:		CAD GENERATED DRAWING, DO NOT MANUALLY UPDATE		
FRACTIONS DECIMALS ANGLES		APPROVALS	DATE	
±	.XX ±.02 .XXX ±.005	DRAWN	02/05/14	
MATERIAL		CHECKED		
FINISH		RESP ENG		
DO NOT SCALE DRAWING		MFG ENG		
MASS 0.100 LBS		SCALE 1:1	SHEET 1 OF 1	

Control Devices LLC
1555 LARKIN WILLIAMS ROAD, FENTON MO 63026

MINI FV, PVC, 1/4

SIZE B DWG. NO. MA2S2 REV. A