

D

C

B

A

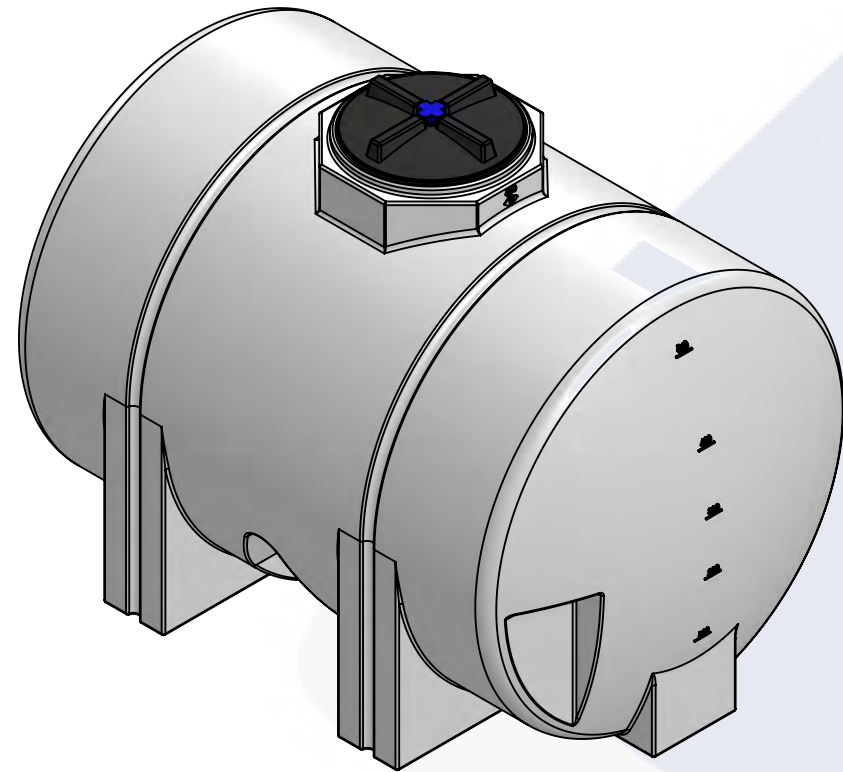

ISOMETRIC VIEW

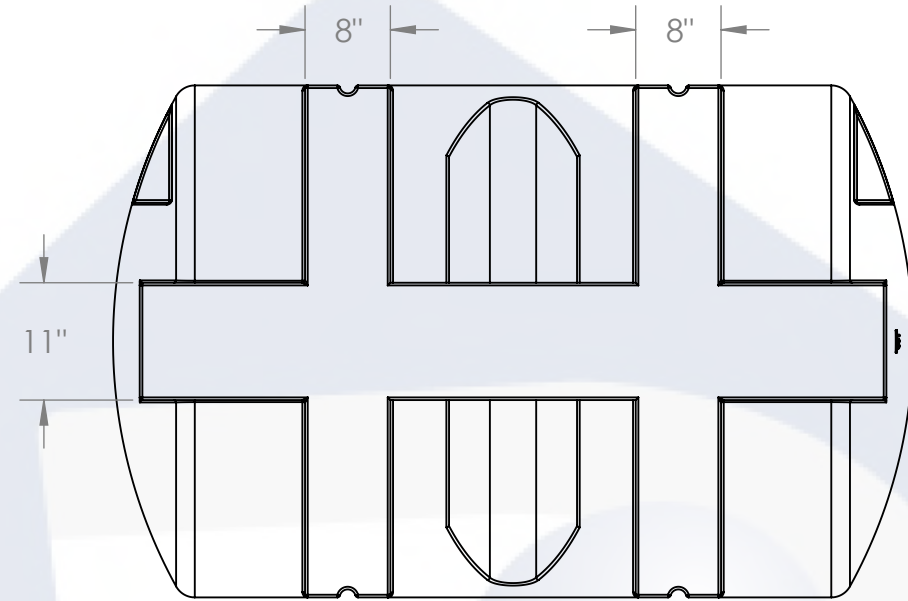

BOTTOM VIEW

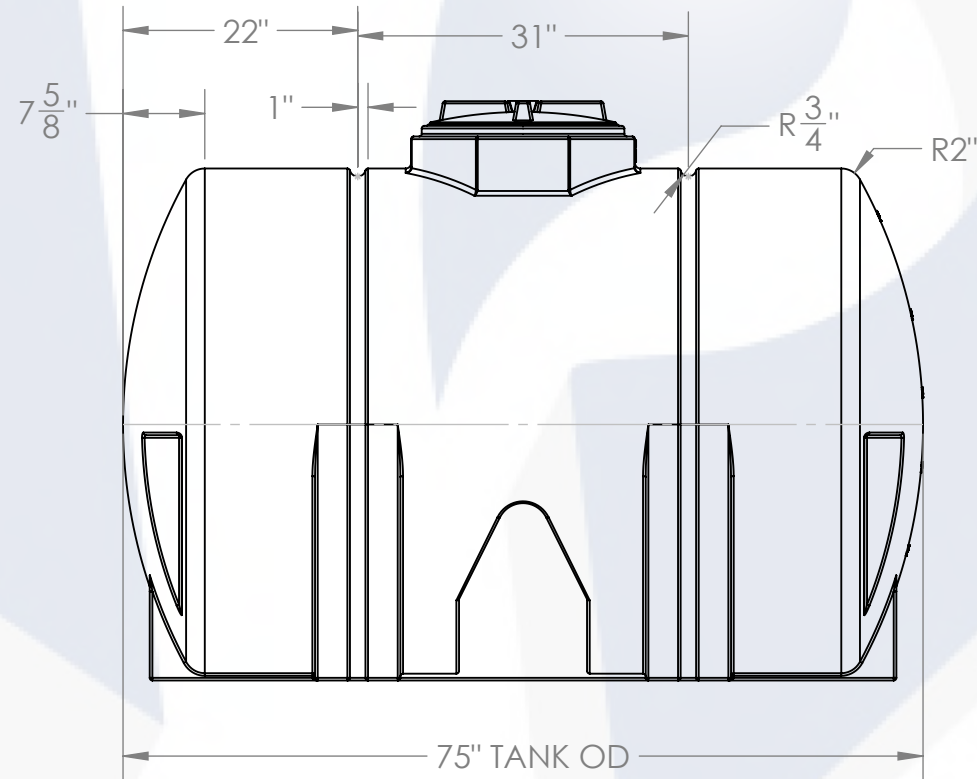

SIDE VIEW

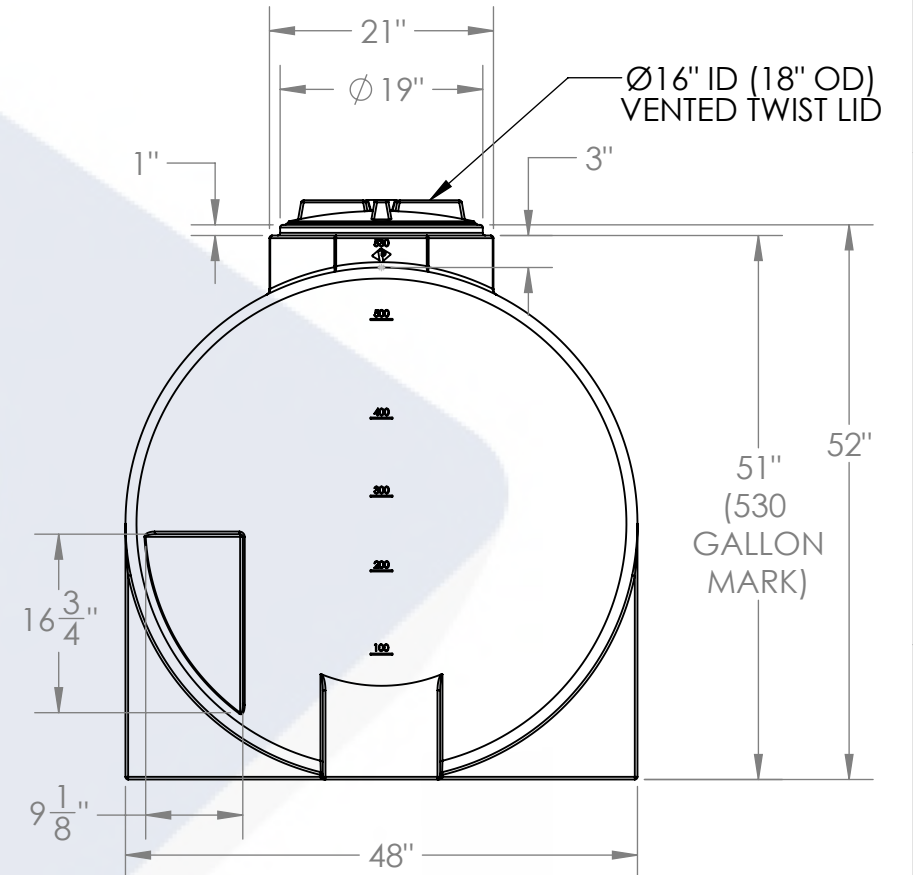

FRONT VIEW

NOTES:

1. CAPACITY: 530 GAL. NOMINAL
2. APPROXIMATE WEIGHT: 135 LBS
3. TANK MATERIAL: LLDPE W/ UV INHIBITOR
4. SERVICE PRESSURE: ATMOSPHERIC

530G HORIZONTAL PROCHEM	PART NUMBER		
	PROCESS CHEMICAL (NATURAL)	POTABLE WATER (BLACK)	WEIGHT (LBS)
LPE (1.5)	01-35538	N/A	135
LPE (1.9)	01-35543	N/A	155
XLPE (1.9)	01-35549	N/A	N/A
ALTERNATIVE MATERIALS, COLOR, AND ACCESSORIES ARE AVAILABLE. CALL FOR ADDITIONAL INFO			

UNLESS OTHERWISE SPECIFIED:

DIMENSIONS ARE IN INCHES
 TOLERANCES: ±1/4"
 ANGULAR: ±.5°
 ONE PLACE DECIMAL: ±.25
 TWO PLACE DECIMAL: ±.125
 THREE PLACE DECIMAL: ±.063

TANK MATERIAL: LPE 1.5

INNER TANK S/N:

OUTER TANK S/N:

CUSTOMER PO#

DO NOT SCALE DRAWING

PROPRIETARY AND CONFIDENTIAL

THE INFORMATION CONTAINED IN THIS DRAWING IS THE SOLE PROPERTY OF PEABODY ENGINEERING. ANY REPRODUCTION IN PART OR AS A WHOLE WITHOUT THE WRITTEN PERMISSION OF PEABODY ENGINEERING IS PROHIBITED.

NAME	DATE	PEABODY engineering	
DRAWN: JO	04/01/24	PROJECT:	530G HORIZONTAL PROCHEM
CHECKED:		CUSTOMER:	PEABODY STANDARD
ENG APPR.:		SITE/LOCATION:	
MFG APPR.:		DRAWING#:	
Q.A.:		SIZE: B	DESC. 530G HORIZONTAL PROCHEM
ALTERNATIVE VERSIONS		SCALE: 1:18	REV. A
MATERIALS: XLPE, PPL, PVDF COLORS: NATURAL, BLUE OR BLACK AVAILABLE WITH FRP WRAP		CALL FOR PART NUMBERS	
SHEET 1 OF 1		SCALE: 1:18	