

| BOM | | |
|----------|-------------------------|------|
| ITEM NO. | DESCRIPTION | QTY. |
| 1 | STEEL PIPE, Ø1" SCH 40 | 1 |
| 2 | STEEL PLATE, 1/4" THICK | 2 |

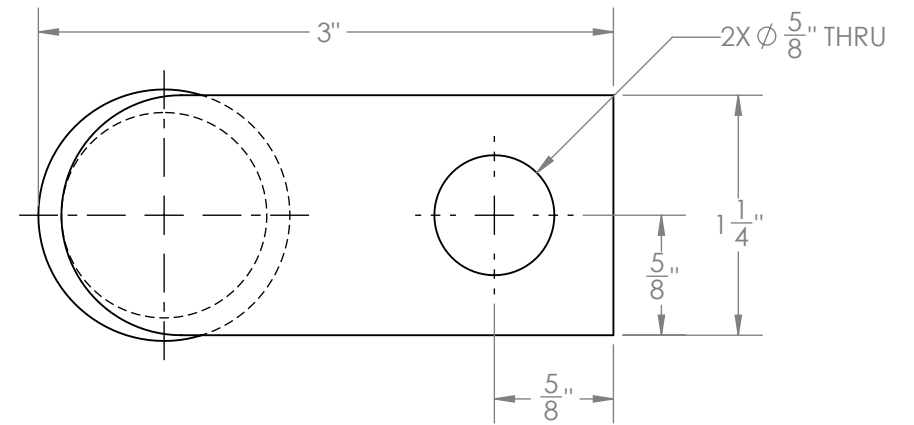

SECTION A-A
SCALE 1 : 1

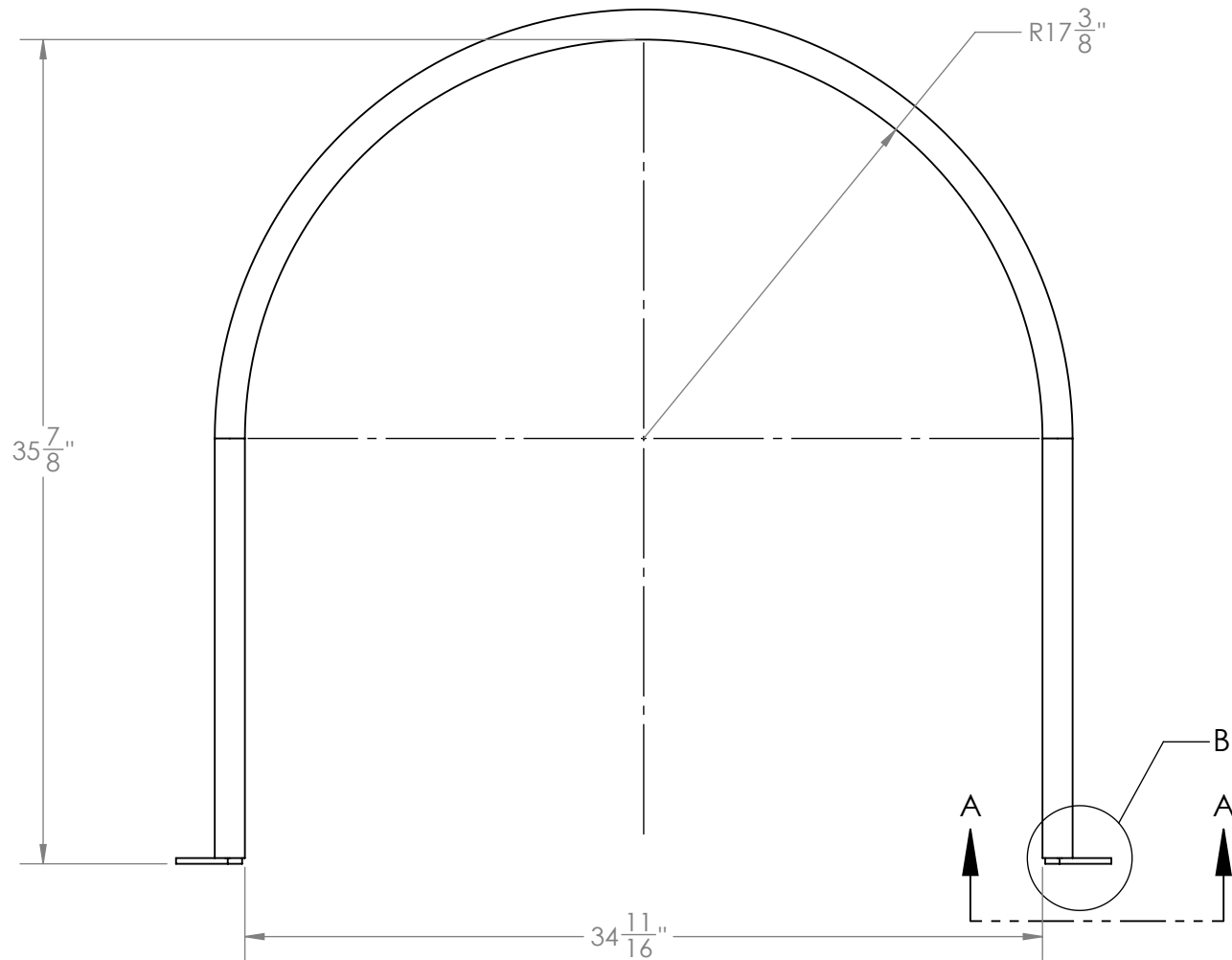
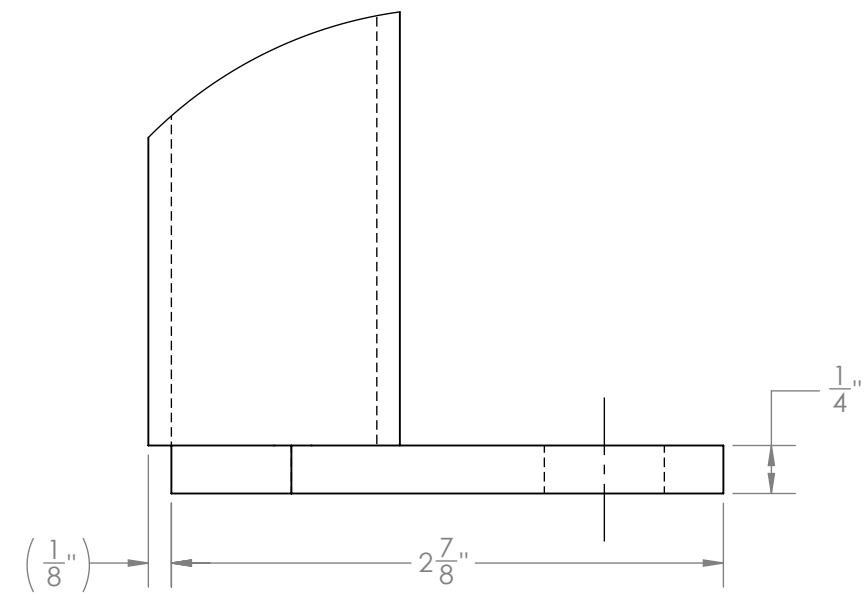

DETAIL B
SCALE 1 : 1

- NOTES:**
- MATERIAL:** ASTM A36 STEEL
 - FINISH:** HOT DIPPED GALVANIZED
 - WELD WITH LOW HYDROGEN ROD & GRIND TO REMOVE SHARP EDEGES**

PROPRIETARY AND CONFIDENTIAL
THE INFORMATION CONTAINED IN THIS DRAWING IS THE SOLE PROPERTY OF PEABODY ENGINEERING. ANY REPRODUCTION IN PART OR AS A WHOLE WITHOUT THE WRITTEN PERMISSION OF PEABODY ENGINEERING IS PROHIBITED.

| UNLESS OTHERWISE SPECIFIED: | | NAME | DATE |  | | | | | | |
|---|-------------------------------|------------|------|--|----------|-------|------|----------|-------------------------------|---|
| DIMENSIONS ARE IN INCHES TOLERANCES: ±1/4" ANGULAR: ±.5° ONE PLACE DECIMAL ±.3" TWO PLACE DECIMAL ±.13" THREE PLACE DECIMAL ±.063" | | DRAWN | ETP | | 11/27/23 | | | | | |
| TANK MATERIAL: | | CHECKED | | PROJECT: PROCHEM TANKS | | | | | | |
| INNER TANK S/N: | | ENG APPR. | | CUSTOMER: PEABODY STANDARD | | | | | | |
| OUTER TANK S/N: | | MFG APPR. | | SITE/LOCATION: FOB: LIBERTY, SC | | | | | | |
| CUSTOMER PO# | | Q.A. | | SALES ORDER#: | | | | | | |
| DO NOT SCALE DRAWING | | COMMENTS: | | <table border="1"> <tr> <th>SIZE</th> <th>DESC.</th> <th>REV.</th> </tr> <tr> <td>B</td> <td>BAND, 330G HORIZ TANKS</td> <td>-</td> </tr> </table> | SIZE | DESC. | REV. | B | BAND, 330G HORIZ TANKS | - |
| SIZE | DESC. | REV. | | | | | | | | |
| B | BAND, 330G HORIZ TANKS | - | | | | | | | | |
| | | SCALE: 1:8 | | LAST SAVED: Monday, November 27, 2023 2:55:47 PM SHEET 1 OF 1 | | | | | | |