

BOM		
ITEM NO.	DESCRIPTION	QTY.
1	STEEL PIPE, Ø1" SCH 40	1
2	STEEL PLATE, 1/4" THICK	2

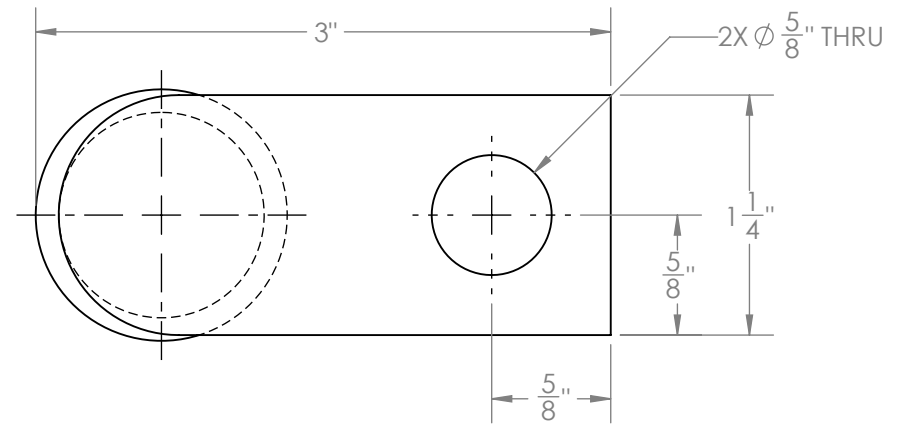

**SECTION A-A**  
SCALE 1 : 1

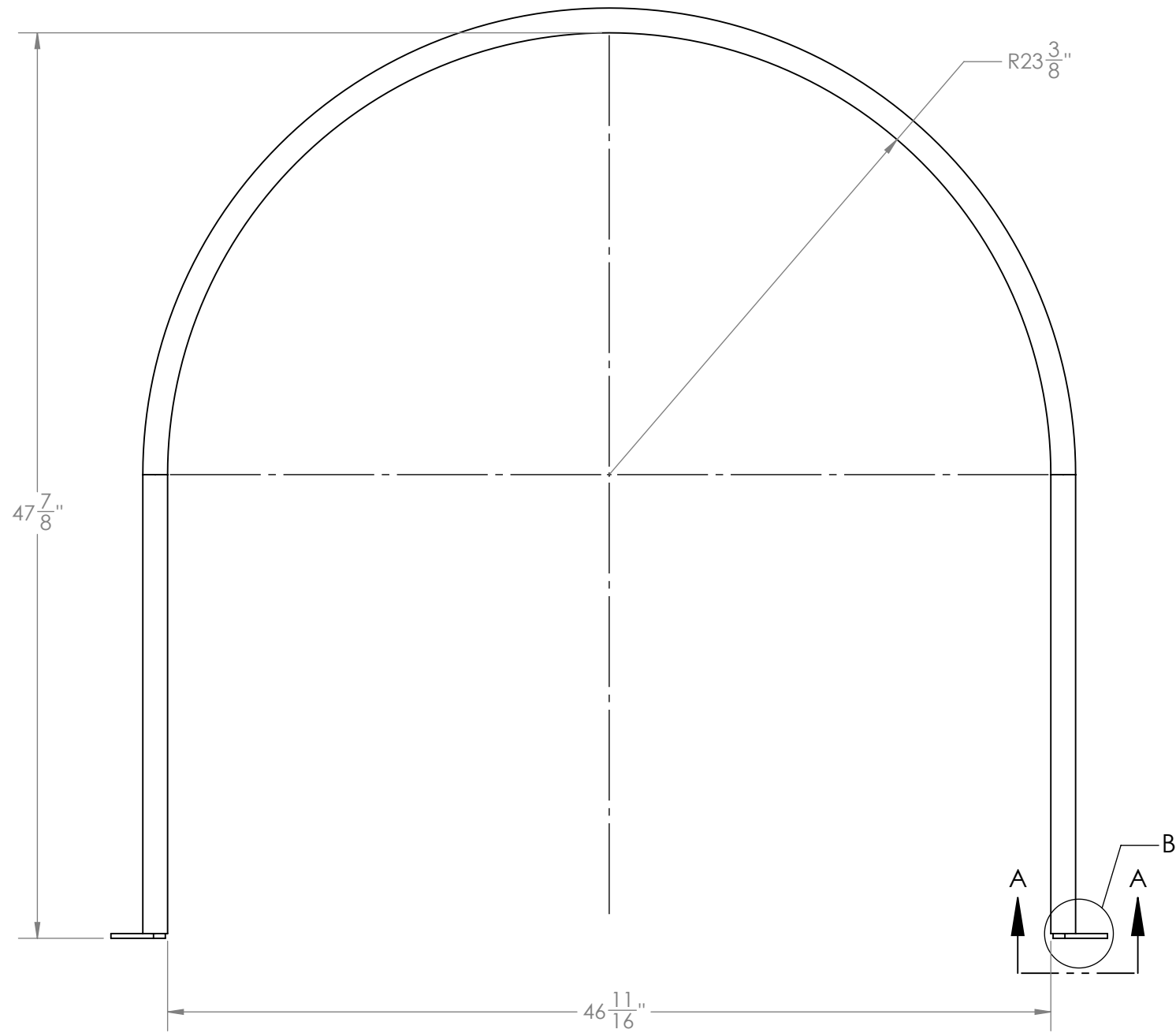
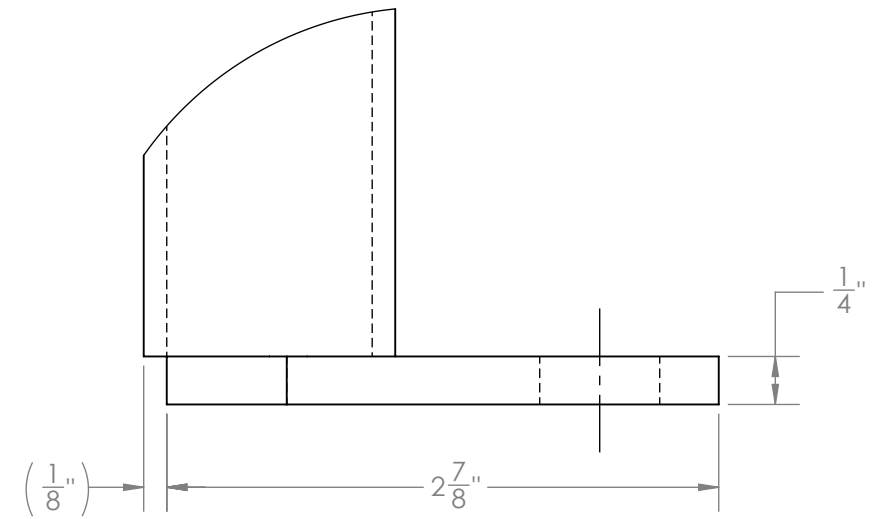

**DETAIL B**  
SCALE 1 : 1

- NOTES:**
- MATERIAL:** ASTM A36 STEEL
  - FINISH:** HOT DIPPED GALVANIZED
  - WELD WITH LOW HYDROGEN ROD & GRIND TO REMOVE SHARP EDEGES**

**PROPRIETARY AND CONFIDENTIAL**  
THE INFORMATION CONTAINED IN THIS DRAWING IS THE SOLE PROPERTY OF PEABODY ENGINEERING. ANY REPRODUCTION IN PART OR AS A WHOLE WITHOUT THE WRITTEN PERMISSION OF PEABODY ENGINEERING IS PROHIBITED.

UNLESS OTHERWISE SPECIFIED:		NAME	DATE							
DIMENSIONS ARE IN INCHES TOLERANCES: ±1/4" ANGULAR: ±.5° ONE PLACE DECIMAL ±.3" TWO PLACE DECIMAL ±.13" THREE PLACE DECIMAL ±.063"		DRAWN	ETP		11/27/23					
TANK MATERIAL:		CHECKED		PROJECT: PROCHEM TANKS						
INNER TANK S/N:		ENG APPR.		CUSTOMER: PEABODY STANDARD						
OUTER TANK S/N:		MFG APPR.		SITE/LOCATION: FOB: LIBERTY, SC						
CUSTOMER PO#		Q.A.		SALES ORDER#:						
DO NOT SCALE DRAWING		COMMENTS:		<table border="1"> <tr> <th>SIZE</th> <th>DESC.</th> <th>REV.</th> </tr> <tr> <td><b>B</b></td> <td>BAND, 530G HORIZ TANKS</td> <td>-</td> </tr> </table>	SIZE	DESC.	REV.	<b>B</b>	BAND, 530G HORIZ TANKS	-
SIZE	DESC.	REV.								
<b>B</b>	BAND, 530G HORIZ TANKS	-								
		LAST SAVED: Monday, November 27, 2023 2:54:30 PM		SHEET 1 OF 1						