

Copyright. All information furnished within this document, electronic file or design correspondence is the property of Den Hartog Industries, Inc. and shall not be used, disclosed to others or copied without the expressed written consent of Den Hartog Industries, Inc.

Ⓐ REFERENCE PUBLICATION 10039 FOR SEPTIC TANKS OR PUBLICATION 10149 FOR CISTERN TANKS FOR SPECIFIC INSTALLATION GUIDELINES.

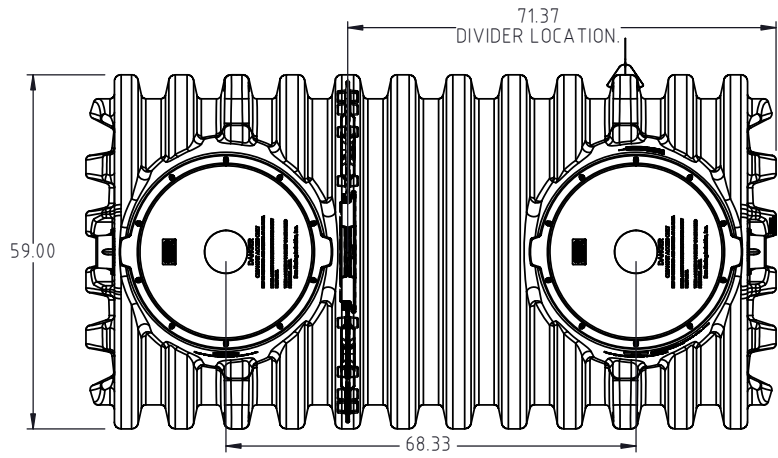

TYPICAL ENGRAVING

TANK CAPACITY	1250 Gallons
DATE OF MANUFACTURE	Month/Year molded
DATE OF ASSEMBLY	Month/Year assembled
SERIAL NUMBER	Sequential serial number
STATE/LOCATION	State assembled for (if applicable)

MAX. BURIAL DEPTH TO TOP OF TANK - 3 FT.

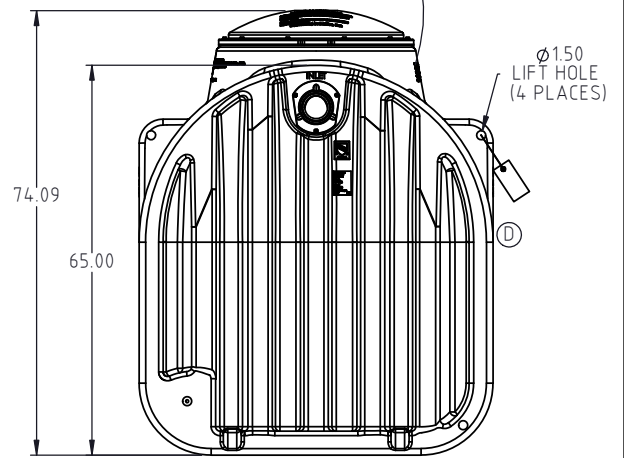
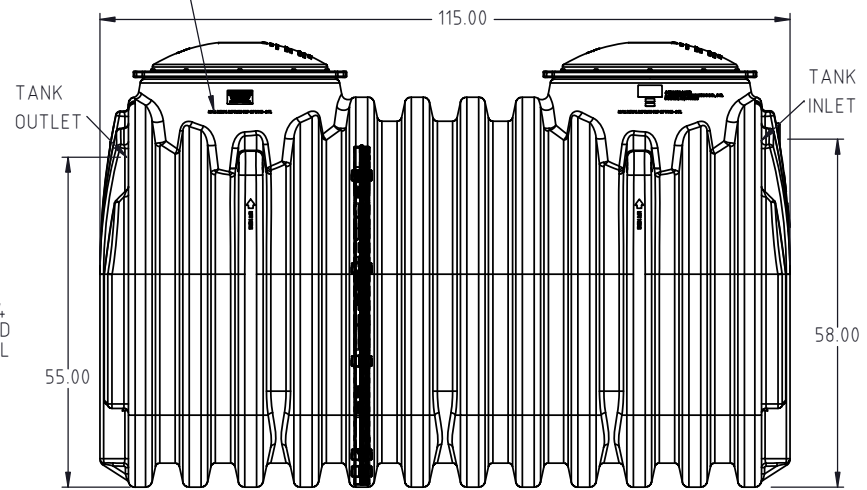
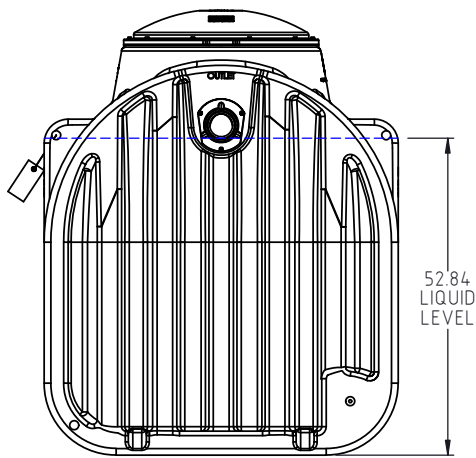

E	TANK/LID DESIGN/PRINT LAYOUT UPDATED. 570 WAS 412. 0.375 WAS 0.250.	ADH	11/26/2024	4673	DRAWN / DATE	MATERIAL : SEE COMPONENTS.
D	11331 WAS 11194.	ADH	5/7/2018	3553	REH 3/15/2004	
C	PRINT DIMENSIONS/LAYOUT UPDATED. NSF GRAPHIC REMOVED.	ADH	2/28/2017	3354	APPRD. / DATE	
REV.	DESCRIPTION	BY	DATE	CCN	REH 3/15/2004	
ALL DIMENSIONS ARE IN DECIMAL INCHES TOLERANCES UNLESS OTHERWISE SPECIFIED		THIRD ANGLE PROJECTION ANSI 14.5M		SHOT WEIGHT: 570.00 LBS.	NOTES: Ⓔ	
POLYETHYLENE		METAL		SHIPPING WEIGHT: 666.00 LBS.	NOMINAL WALL THICKNESS: 0.375"	
±1% @ 68°F		DECIMAL ± .125" FRACTION ± 1/4" ANGLE ± 1°				

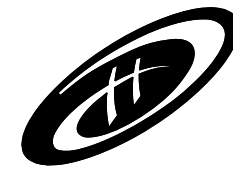

Den Hartog INDUSTRIES, INC.

Ace Roto-Mold • Injection Molding • Blow Molding • Sowjoy
4010 HOSPERS DRIVE S. BOX 425, HOSPERS, IOWA 51238-0425

DESCRIPTION 1250 GAL. TWO COMPARTMENT SEPTIC TANK ASSEMBLY		
SCALE N.S.	PART NO. AST-1250-2	SHEET. 1 OF 1