

Copyright. All information furnished within this document, electronic file or design correspondence is the property of Den Hartog Industries, Inc. and shall not be used, disclosed to others or copied without the expressed written consent of Den Hartog Industries, Inc.

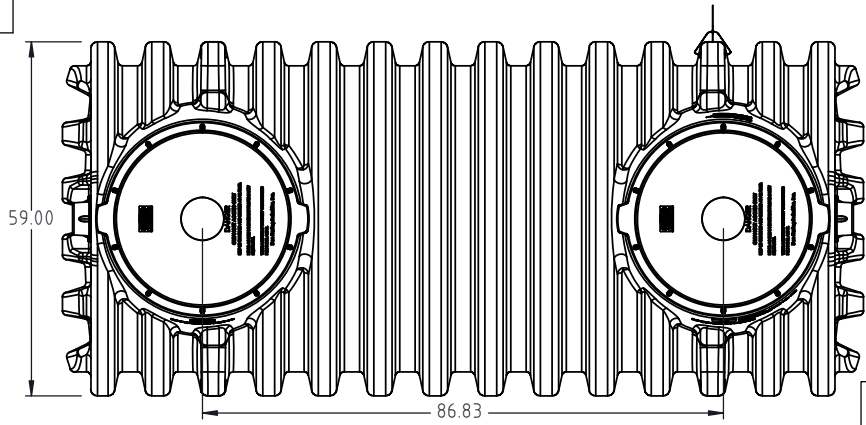

TYPICAL ENGRAVING

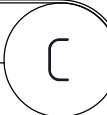
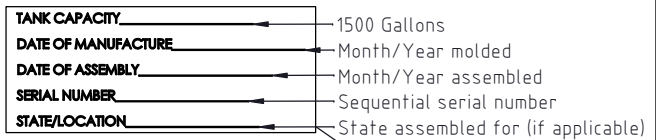

MAX. BURIAL DEPTH TO TOP OF TANK - 3 FT.

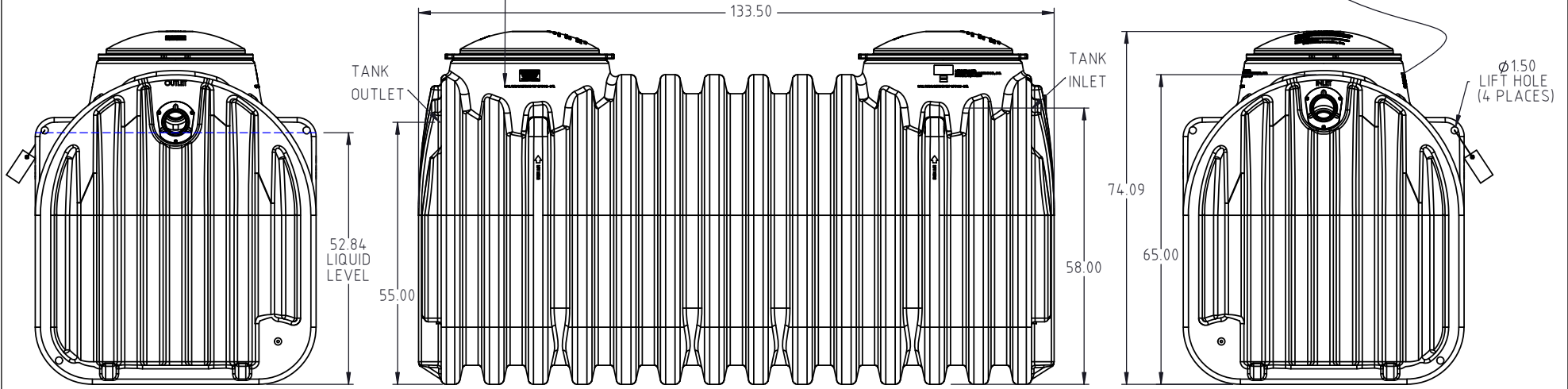

C	TANK/LID DESIGN/PRINT LAYOUT UPDATED. 650 WAS 550. 0.375 WAS 0.250	ADH	11/26/2024	4616	DRAWN / DATE	MATERIAL : SEE COMPONENTS.
B	550.00 LBS WAS 500.00 LBS. PRINT LAYOUT UPDATED.	ADH	3/1/2017	3358	REH 3/15/2004	
A	ADD PUBLICATION REF.	NVE	9/30/2005		APPRD. / DATE	
REV.	DESCRIPTION	BY	DATE	CCN	REH 3/15/2004	
ALL DIMENSIONS ARE IN DECIMAL INCHES TOLERANCES UNLESS OTHERWISE SPECIFIED		THIRD ANGLE PROJECTION ANSI 14.5M		SHOT WEIGHT: 650.00 LBS.	NOTES: Ⓒ	
POLYETHYLENE		METAL		SHIPPING WEIGHT: 700.00 LBS.		
±1% @ 68°F		DECIMAL ± .125" FRACTION ± 1/4" ANGLE ± 1°		FINISH:	NOMINAL WALL THICKNESS: 0.375"	



Den Hartog INDUSTRIES, INC.

Ace Roto-Mold • Injection Molding • Blow Molding • Sowjoy
4010 HOSPERS DRIVE S. BOX 425, HOSPERS, IOWA 51238-0425

DESCRIPTION		1500 GAL. SINGLE COMPARTMENT SEPTIC TANK ASSEMBLY	
SCALE	N.S.	PART NO.	AST-1500-1
		SHEET	1 OF 1