

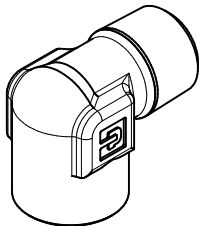

CUSTOMER PRINT

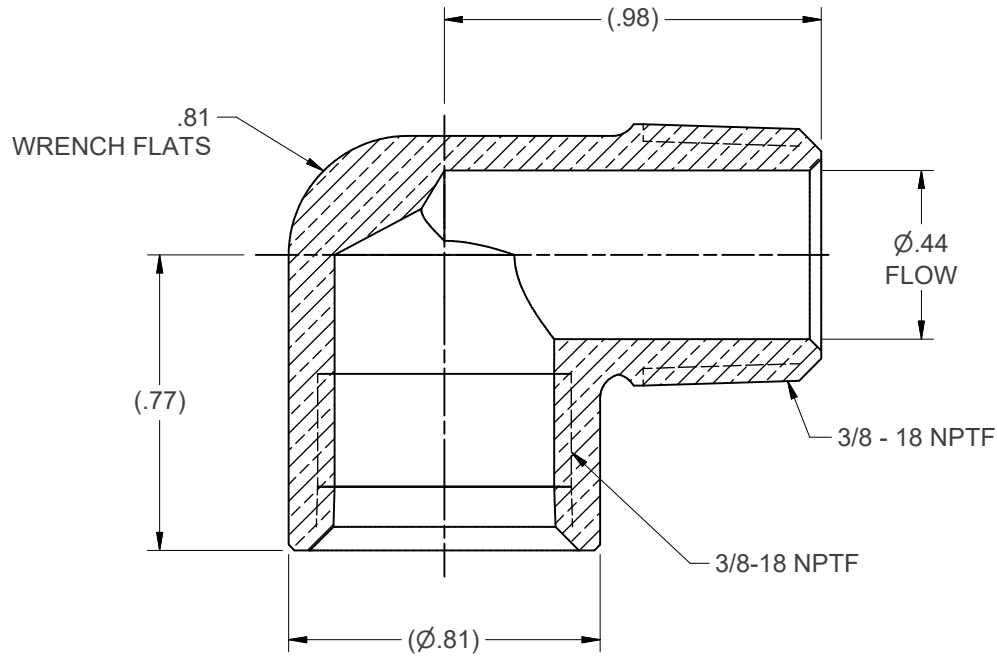
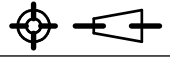

0.119 lbmass	0.391 in ³		UNS C37700 BRASS	DESCRIPTION
EST. WEIGHT	EST. VOLUME		MATERIAL	
 FLUID SYSTEM CONNECTORS DIVISION		INCH		90° STREET ELBOW
		DRAWN BY: TECHM	DRAWN DATE: 6/20/2022	
<small>THIS DOCUMENT CONTAINS INFORMATION THAT IS CONFIDENTIAL AND PROPRIETARY TO PARKER-HANNIFIN CORPORATION. THIS DOCUMENT IS FURNISHED ON THE UNDERSTANDING THAT THE DOCUMENT AND THE INFORMATION IT CONTAINS WILL NOT BE COPIED OR DISCLOSED TO OTHERS OR USED FOR ANY PURPOSE OTHER THAN CONDUCTING BUSINESS WITH PARKER, AND WILL BE RETURNED AND ALL FURTHER USE DISCONTINUED UPON REQUEST BY PARKER. THE RECIPIENT OF THIS DOCUMENT THROUGH ITS OWN ANALYSIS AND TESTING IS SOLELY RESPONSIBLE FOR MAKING THE FINAL SELECTION OF THE APPLICABLE SYSTEM AND COMPONENTS AND ASSURING THAT ALL PERFORMANCE, ENDURANCE, MAINTENANCE, SAFETY AND WARNING REQUIREMENTS OF THE APPLICATION ARE MET. COPYRIGHT PARKER. YEAR OF COPYRIGHT IS FIRST YEAR INDICATED ON THIS DOCUMENT. ALL RIGHTS RESERVED.</small>				PART NUMBER 1202P-6-6
				REV. K