

PART. IMBOCCATURA SCALA 5 : 1

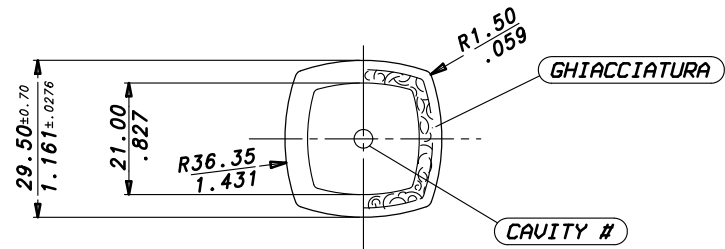
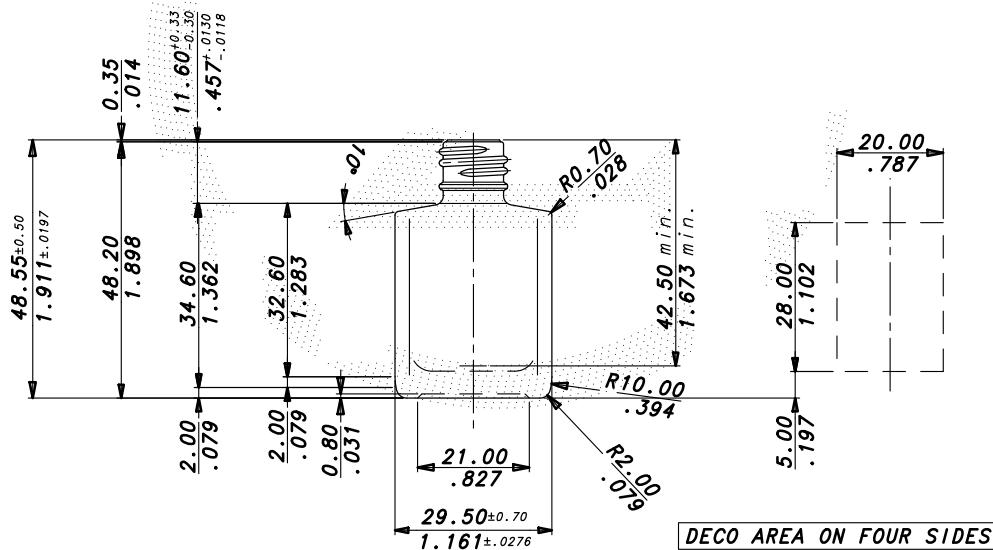

DISEGNO SUSCETTIBILE DI MODIFICHE DA PARTE DEL FORNITORE
DRAWING SUBJECT TO MODIFICATIONS BY THE SUPPLIER

New High Glass Inc.		STABILIMENTO			
CLIENTE CUSTOMER		SCALA SCALE	1:1- 5:1	3	MODIFICATE DIMENSIONI CORPO ERA 31 gr
ARTICOLO ITEM	FL. RHONE 1/2 oz 13_415	DISEGNO N. DRAWING N.	4811-3	2	AGGIUNTA DECO AREA , CAMBIATO NOME E CARTIGLIO
IMBOCCATURA FINISH	13-415 Sealing Bead	N. RIC.	6519_0	1	AGGIUNTO SEALING BEAD
CAPACITA' CAPACITY	RB 16.5 ^{+0.6} / _{-0.6} cc	DATA DATE	03/07/1995	REV DESCRIZIONE DATA	
PESO WEIGHT	28 gr	Uff. Ric.	A/CES	DG	DC
		DISEGN.	Tenani	UPRO	SAT
		APPROV.		NHG	VE/B
		APPR. BY		A/FI	
			LE MISURE SONO IN mm DIMENSIONS IN MILLIMETERS		
			E LE TOLLERANZE SE NON ESPRESSE TOLERANCES AS PER ISO 2768-V		
			SONO SECONDO ISO 2768-V UNLESS OTHERWISE SPECIFIED		