

NOTE	DESCRIPTION	NAME	DATE
A	UPDATED CONCEPT 12984-20 FOR MOULD PRODUCTION	RS	10/31/2014

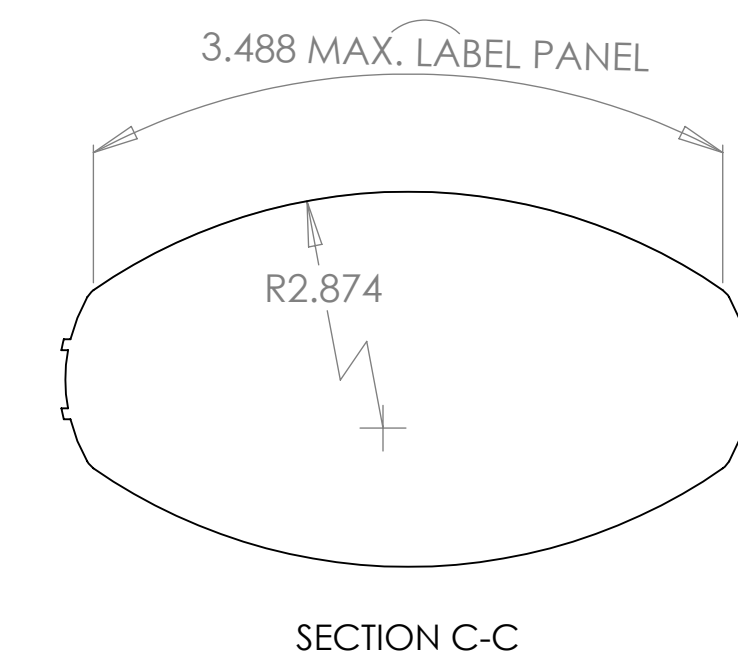

PREFORM STRETCH RATIOS:

HEIGHT: 1.73:1
 WIDTH (P_L): 3.41:1
 DEPTH (F TO B): 2.13:1

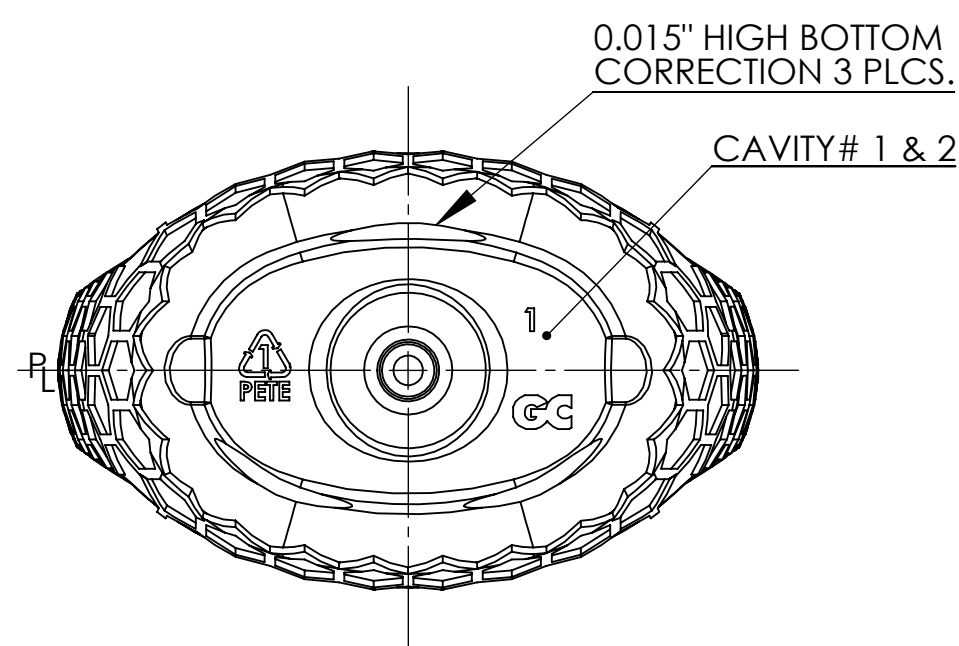
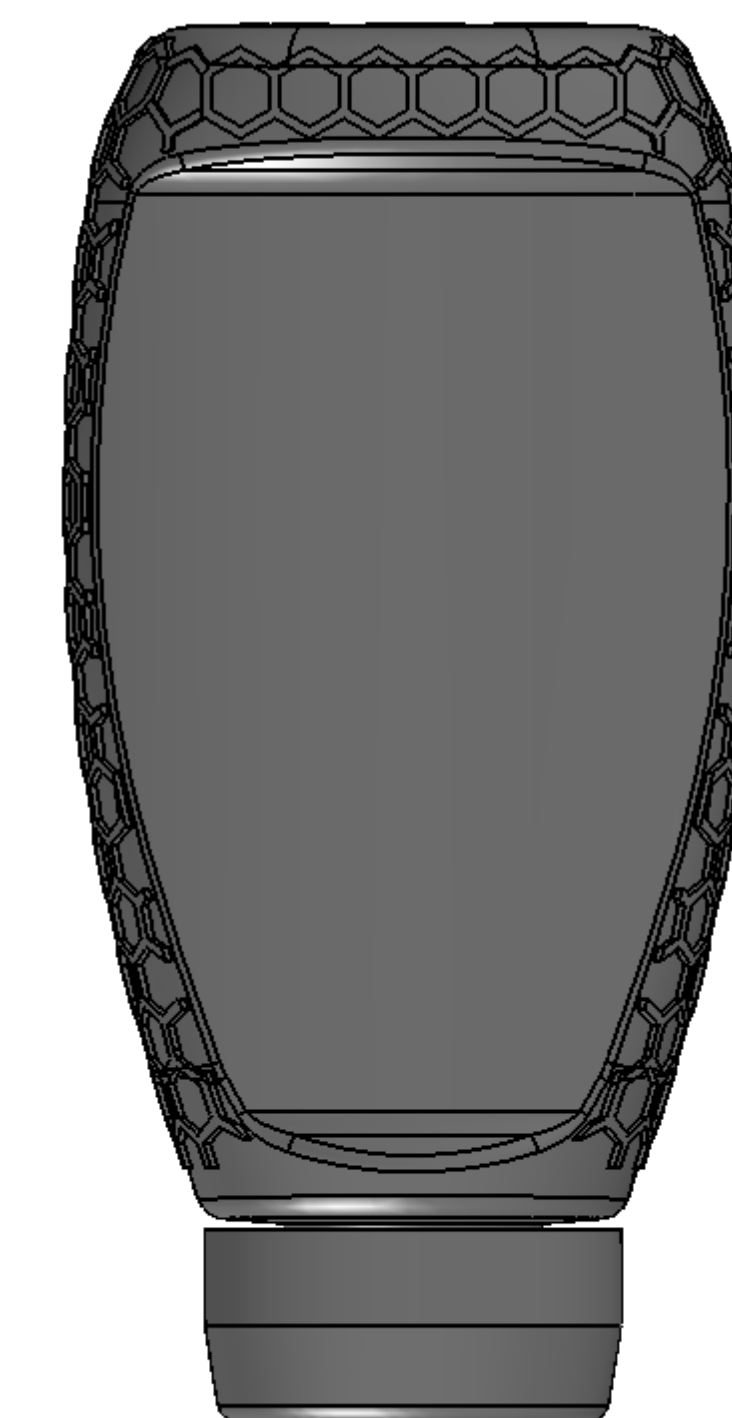
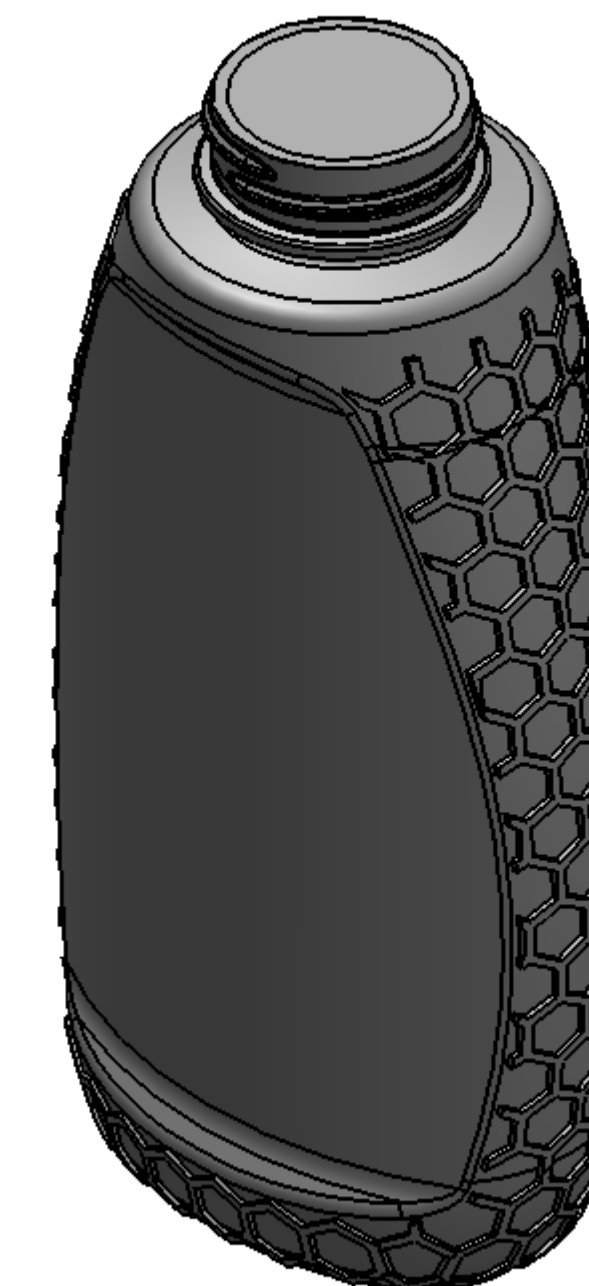
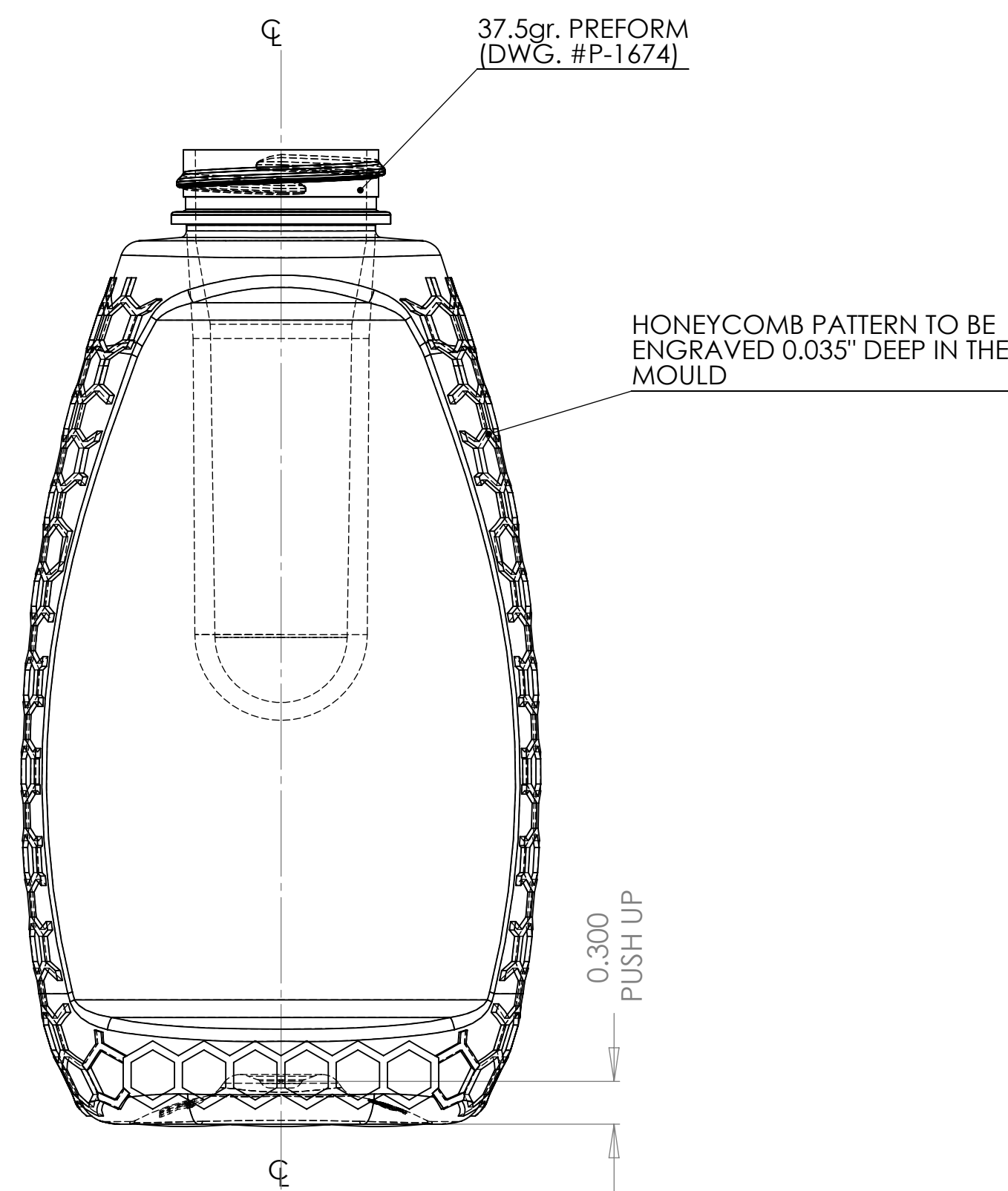
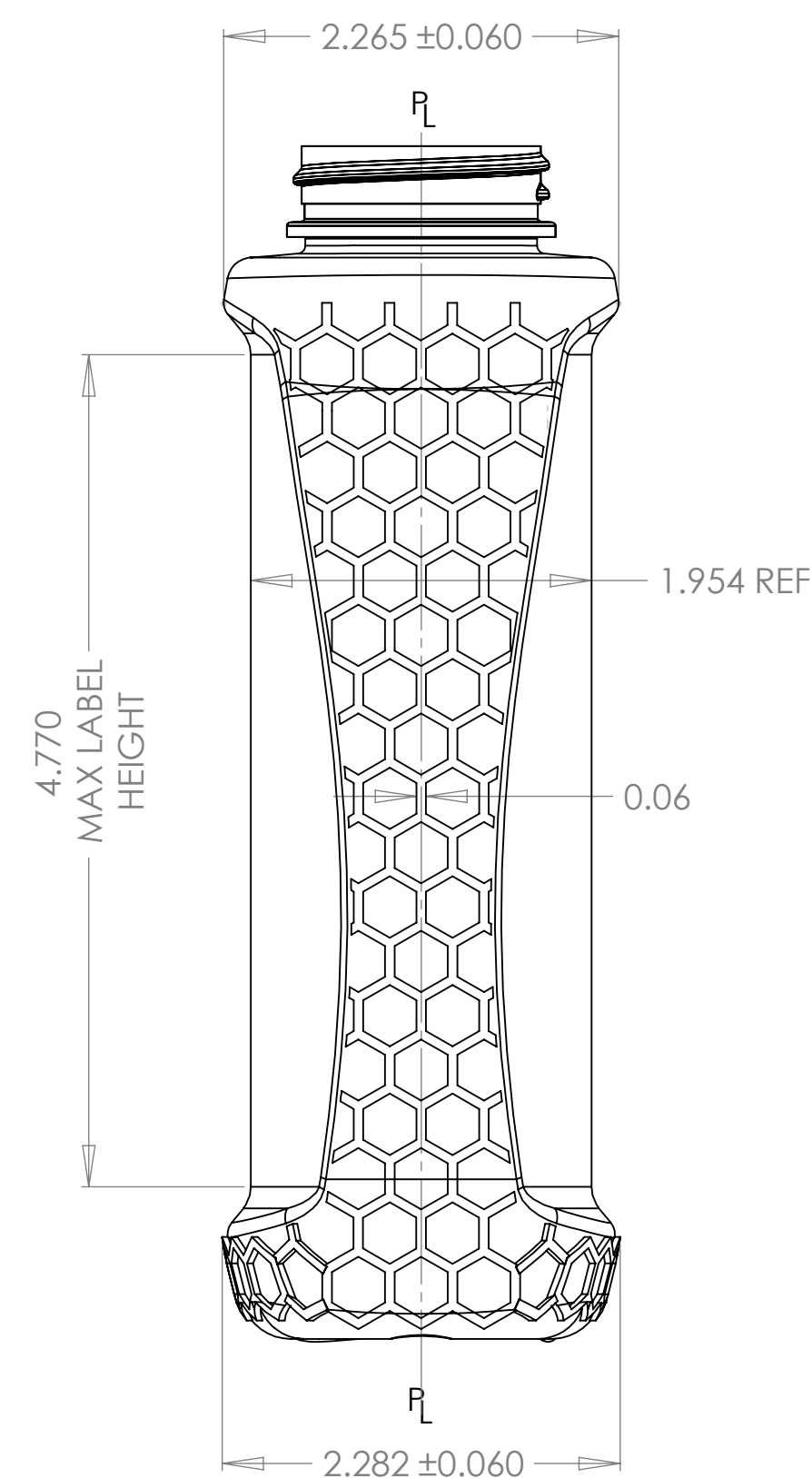
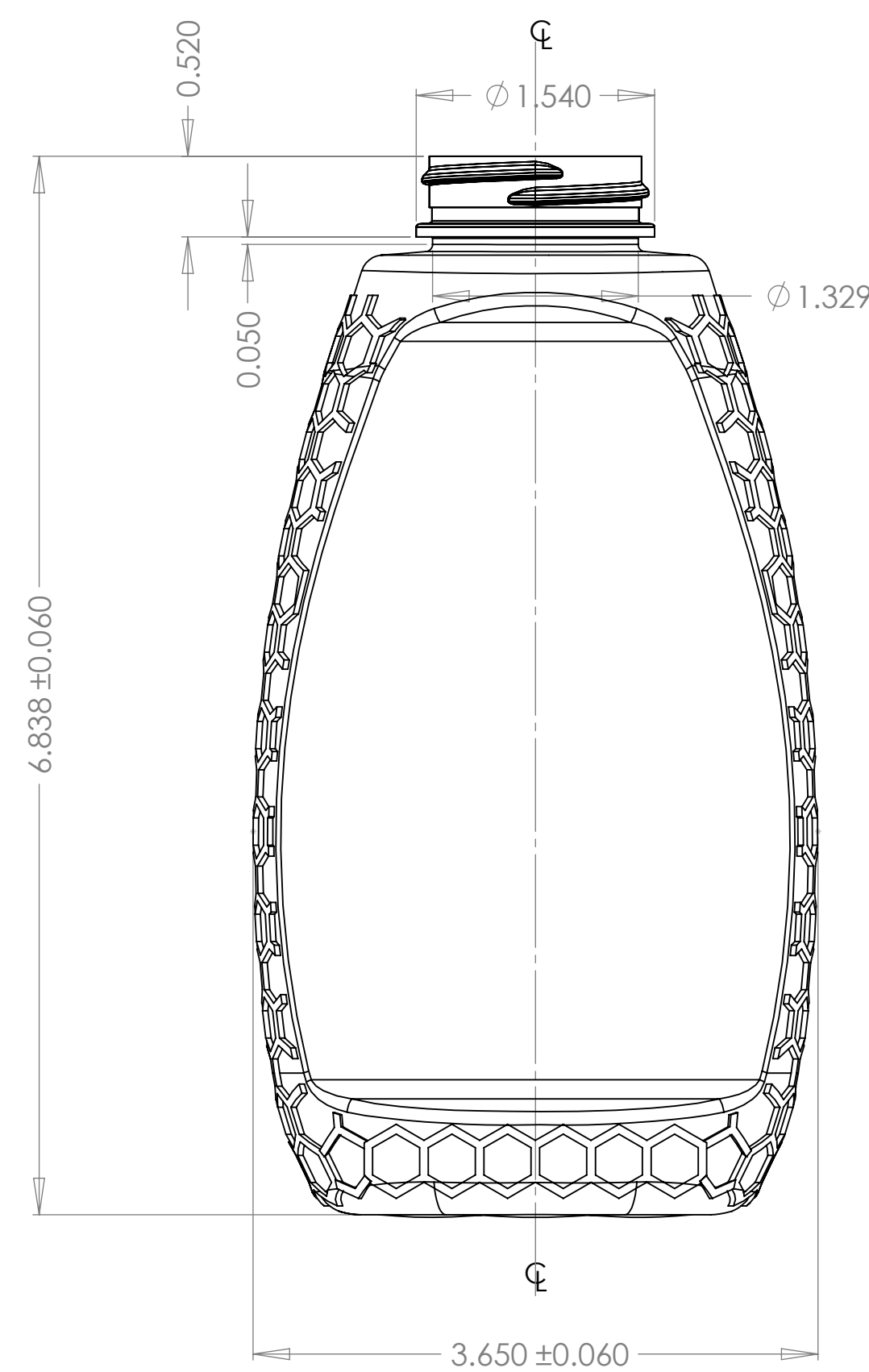
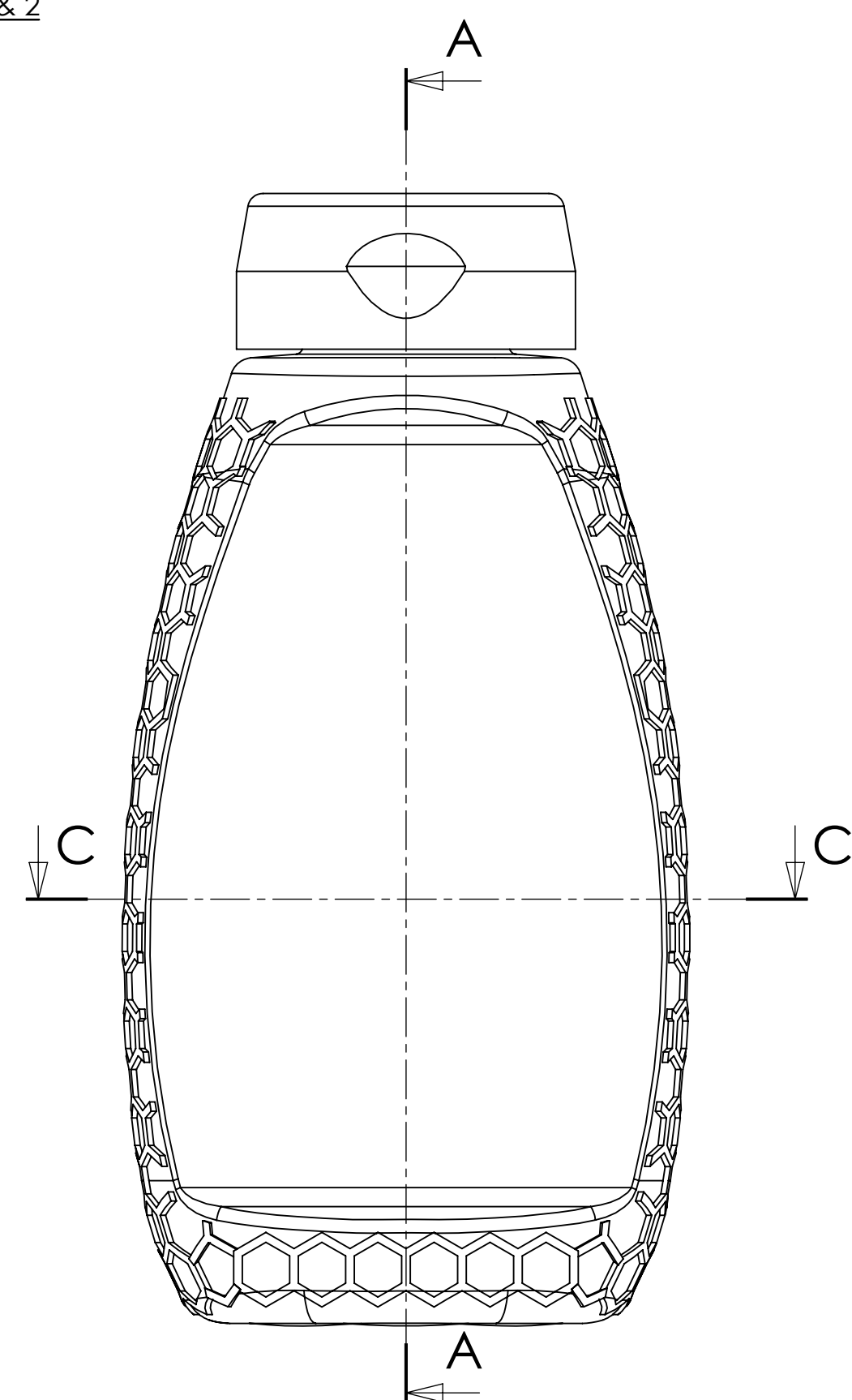

SECTION A-A

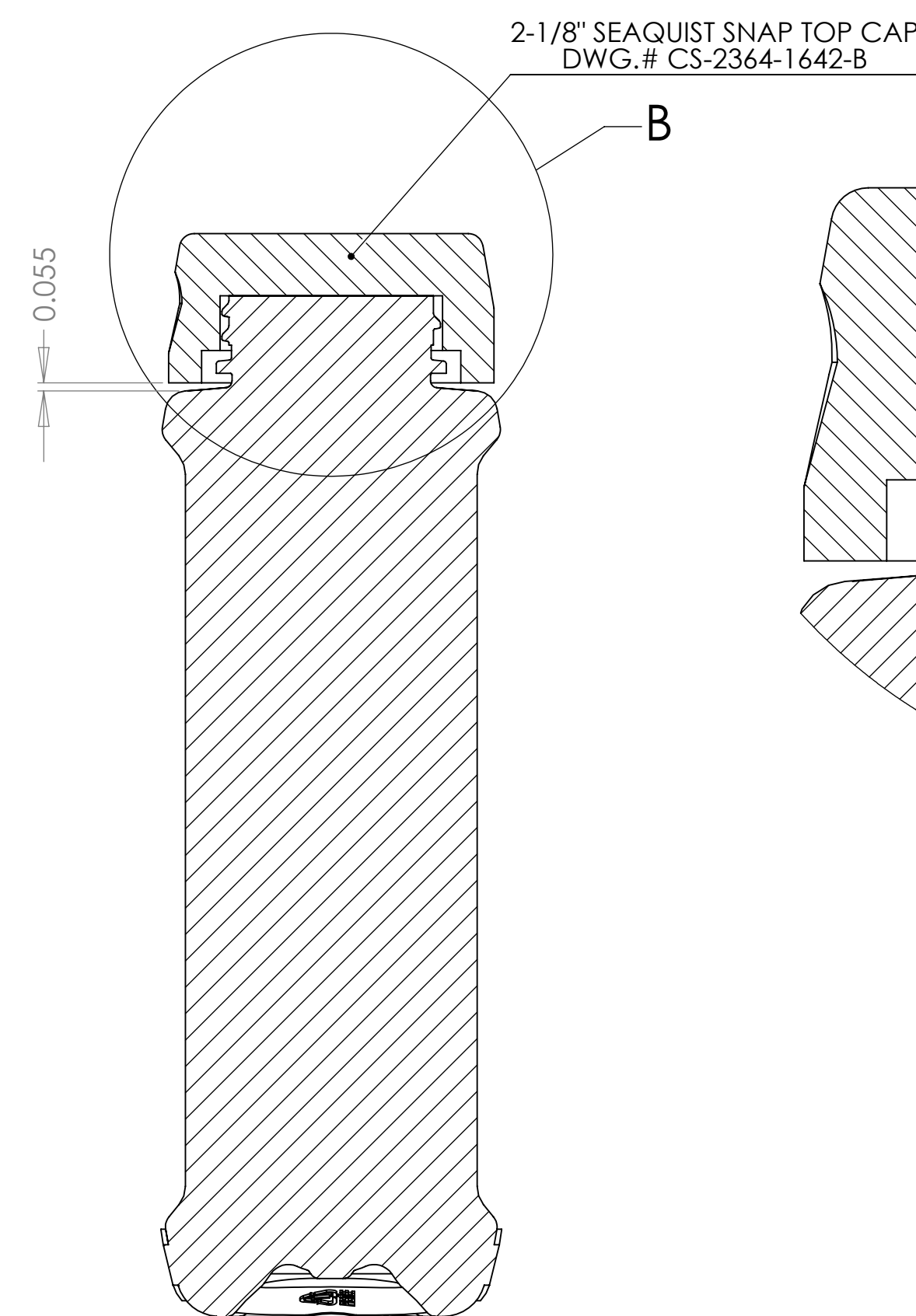

DETAIL B SCALE 2.5 : 1

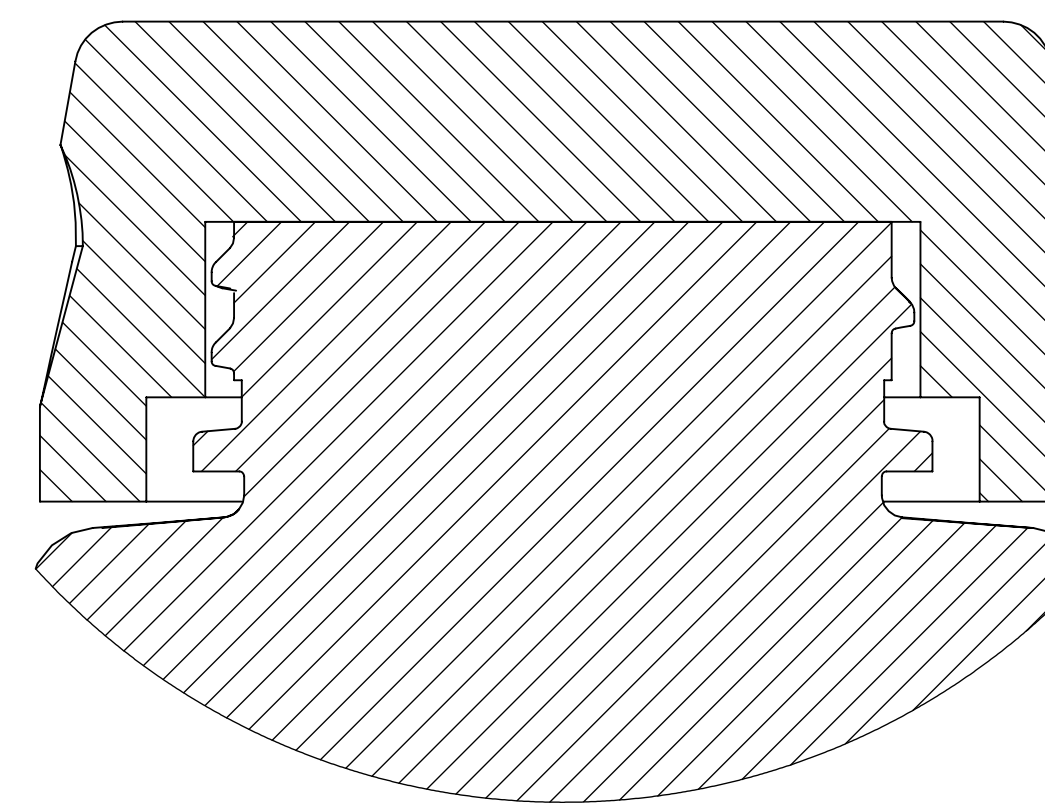

HONEYCOMB PATTERN SHOWN STRAIGHT WALL IN THE DRAWING WILL HAVE DRAFT ANGLE OF 15 DEG./SIDE IN MOULD. THE PATTERN CLOSE TO PARTINGLINE WILL HAVE DRAFT ANGLE OF -25° TO EASE EJECTION OF BOTTLE. (SIMILAR TO 16oz. HONEYCOMB PATTERN)

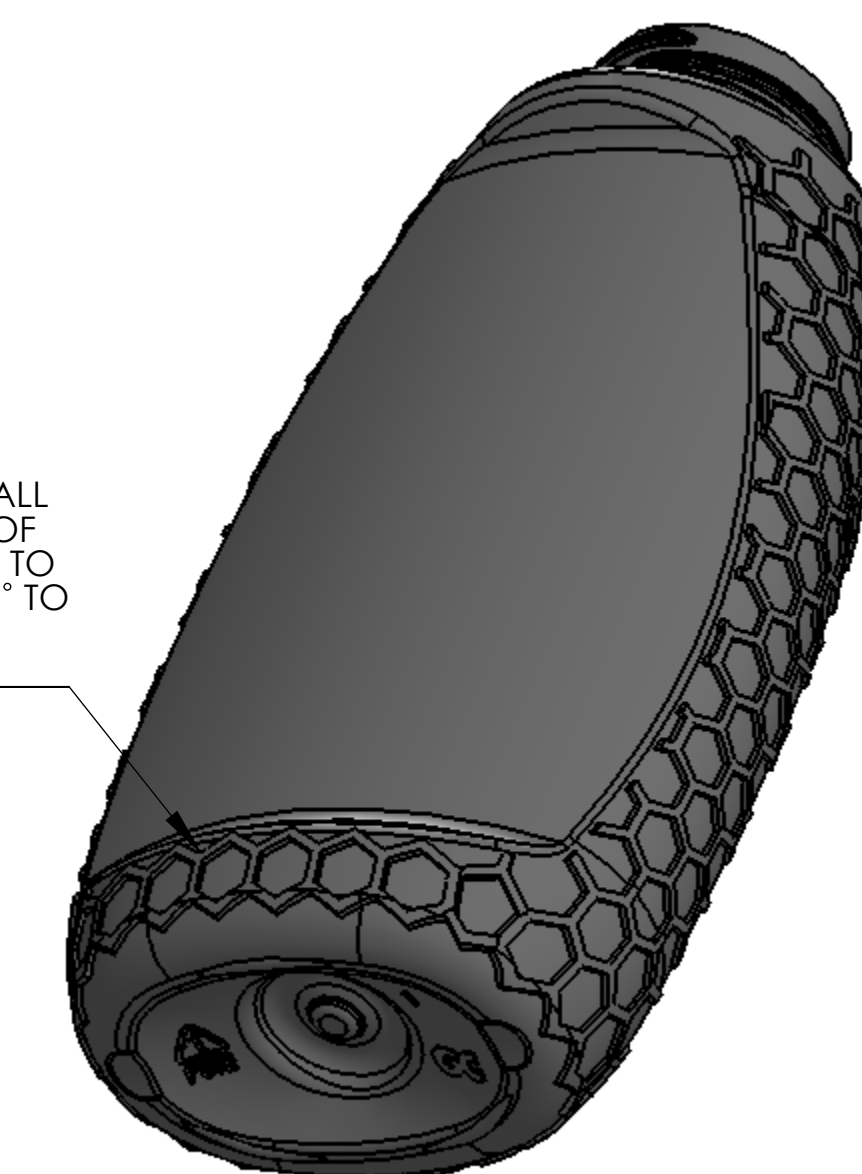

NOTE:		PROPRIETARY AND CONFIDENTIAL		PARKER PLASTICS INC.	
OVERFLOW VOLUME AND FILL LEVEL ARE BASED ON WATER AT 20° C AFTER 72 Hrs.		THE INFORMATION CONTAINED IN THIS DRAWING IS CONFIDENTIAL. ANY REPRODUCTION IN PART OR AS A WHOLE WITHOUT THE WRITTEN PERMISSION OF HALINK RSB INC. IS PROHIBITED.		24oz. HONEYCOMB INVERTED	
BOTTLE OVERFLOW CAPACITY:	PART WEIGHT:	SHEET SIZE:			
504ml ± 11ml	37.5gr	D		CUSTOMER NO. --	
PART DRAWING TO BE APPROVED PRIOR TO MOULD PRODUCTION	MATERIAL: PETE	APPROVALS:	DATE:	This drawing subject to standard industry tolerances. (S.P.I.)	
APPROVED BY: _____	DRAWN: GS 01/11/2011	CHECKED: RS 01/11/2011	ISSUED: GS 01/11/2011	SCALE 1 : 1	SHEET 1 OF 1
DATE: _____	DO NOT SCALE DRAWING				