

Part Number	Description	Retainer	Tether
080075AE	No Vent, No Graphics, Nylon 6/6, BLK	No	No
080077AE	No Vent, Molded DFO, Nylon 6/6, YLW	No	No
080082AE	No Vent, 8" THR, No Graphics, Nylon 6/6, BLK	Yes	8"
080084AE	No Vent, 8" THR, Molded DFO, Nylon 6/6, YLW	Yes	8"
080087AE	No Vent, DFO BLK Ink, Nylon 6/6, YLW	No	No
080088AE	No Vent, No Graphics, Nylon 6/6 YLW	No	No
080089AE	No Vent, 8" THR, DFO WHT Ink, Nylon 6/6, BLK	No	8"
912508A	No Vent, No Graphics, Nylon 6/6 YLW (080087AE)	No	No
912495A	No Vent, No Graphics, Nylon 6/6 BLK (080089AE)	Yes	No

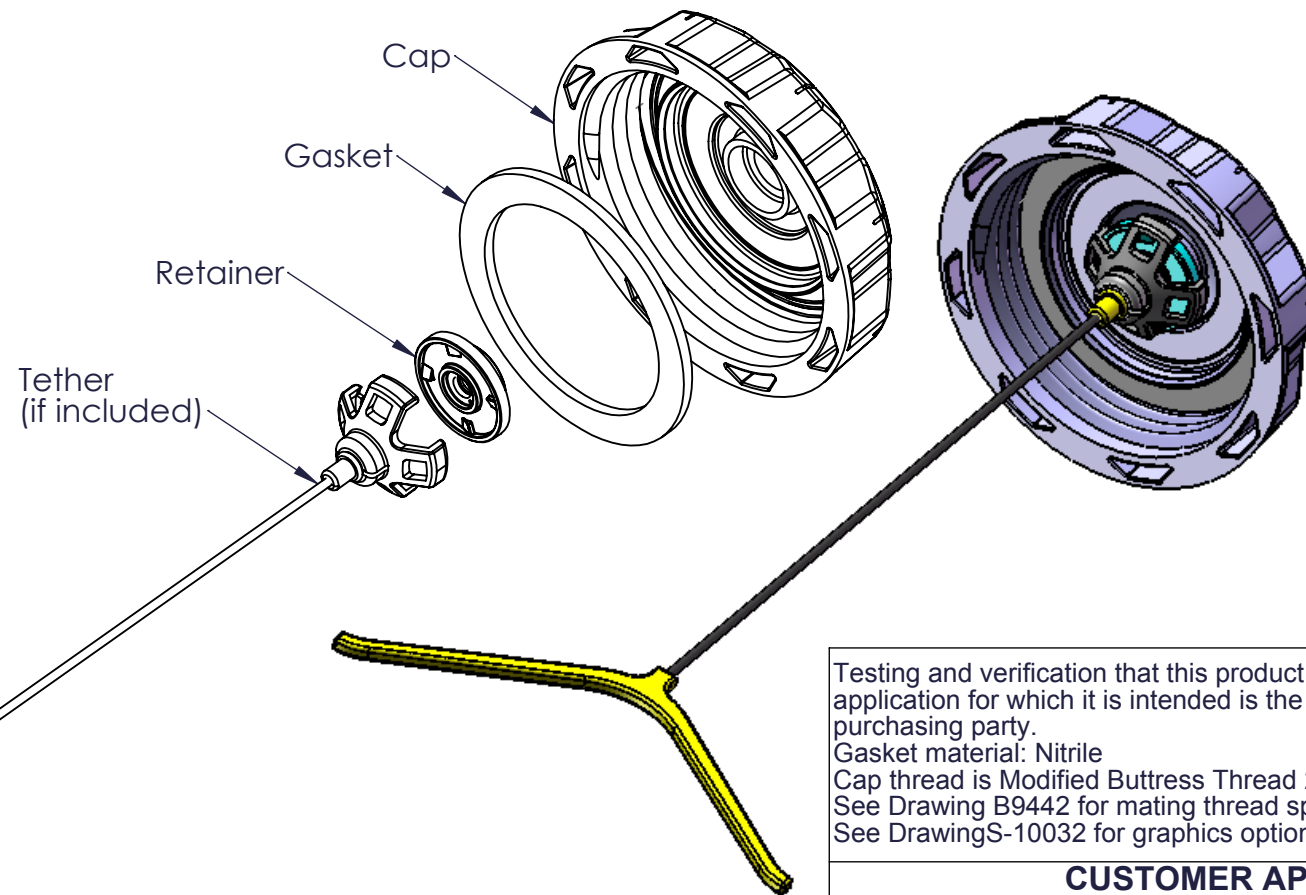
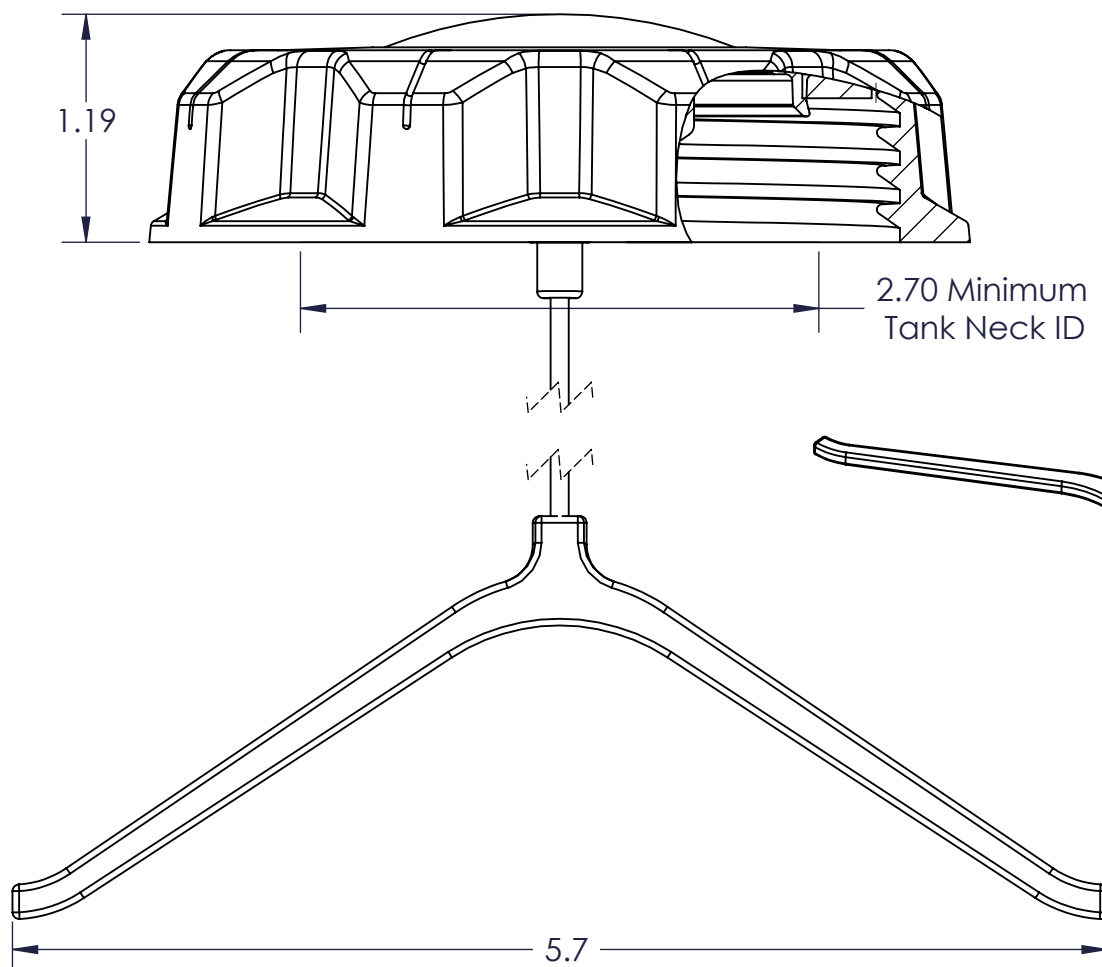

Testing and verification that this product is appropriate for the application for which it is intended is the sole responsibility of the purchasing party.
 Gasket material: Nitrile
 Cap thread is Modified Buttress Thread 2.25" - 5 TPI
 See Drawing B9442 for mating thread specifications.
 See Drawing S-10032 for graphics options.

CUSTOMER APPROVAL

Company Name: _____
 Approved By: _____
 Date: _____
 Part Number: _____

PROPRIETARY AND CONFIDENTIAL
 THE INFORMATION CONTAINED IN THIS DRAWING IS THE SOLE PROPERTY OF FLAMBEAU, Inc. ANY REPRODUCTION IN PART OR AS A WHOLE WITHOUT THE WRITTEN PERMISSION OF FLAMBEAU, Inc. IS PROHIBITED.

DIMENSIONS ARE IN INCHES
 TOLERANCES:
 FRACTIONAL ±1/64"
 ANGULAR: MACH ±.5 BEND ±
 TWO PLACE DECIMAL ±.010"
 THREE PLACE DECIMAL ±.005"
 FOUR PLACE DECIMAL ±.001"

REV.	DESCRIPTION	DATE	BY	APR
A	Released for Production	6-20-08	RDL	DJH

SHT 1

FLAMBEAU INC.
 911 LYNN AVENUE BARABOO, WI 53913 PH. (608)356-5551

Scale: None W.O. No: - - -
 Mold No: NA FPN: See Table
 Mat'l: NA Shrink: NA

3.50" Unvented Fluids Cap Assy

Customer: Flambeau Fluid Systems Drawing #: S-10069