

**© DEN HARTOG INDUSTRIES, INC.**  
 Copyright. All information furnished within this document, electronic file or design correspondence is the property of Den Hartog Industries, Inc. and shall not be used, disclosed to others or copied without the expressed written consent of Den Hartog Industries, Inc.

KEY	PART NUMBER	DESCRIPTION	QTY.
1	10921	LID, 6" ACCESS PLATE WITH RING	1
2	12406	PLUG, 3" PVC WHITE SQUARE HEAD	3
3	10352	LABEL, ACE MEDIUM	1
4	10353	LABEL, WARNING	1
5	10357	LABEL, BARCODE 4" X 2"	1
6	14935	LABEL, PROP 65	1
7	19496	NSF/ANSI/CAN 61 MARKING LABEL	1
8	XXXX	LABEL, INSPECTION	1

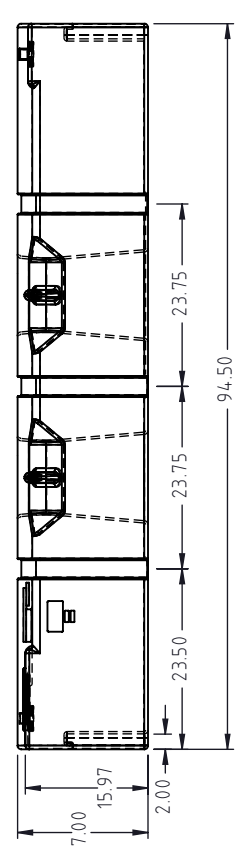
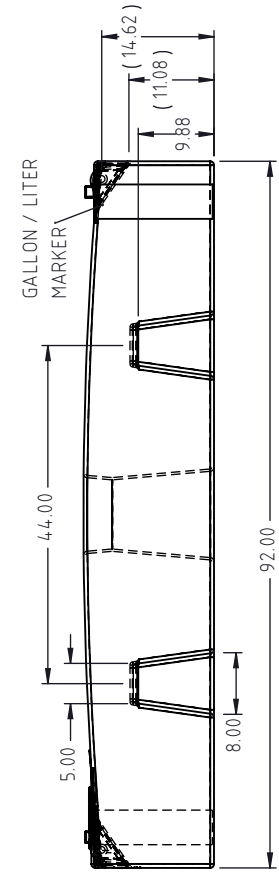
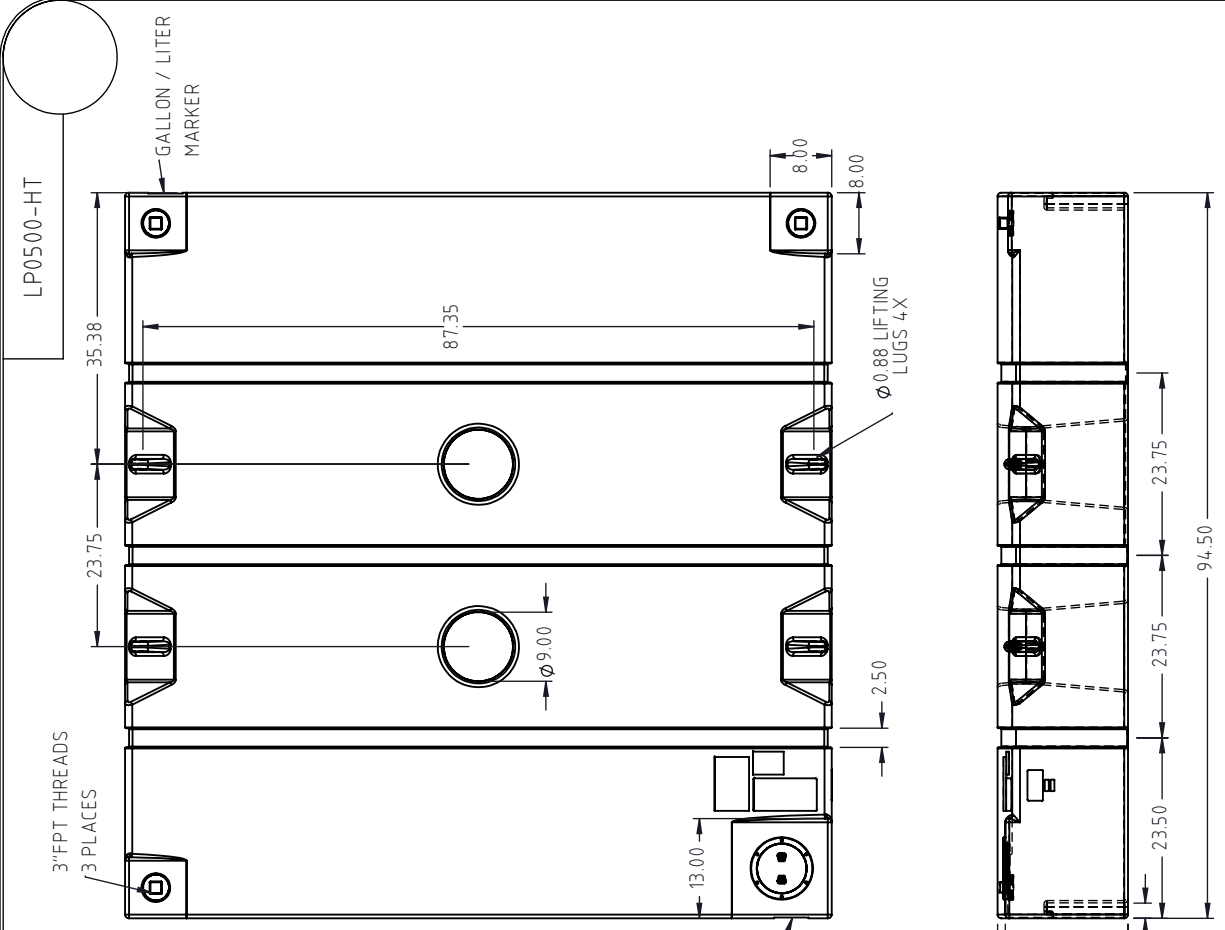
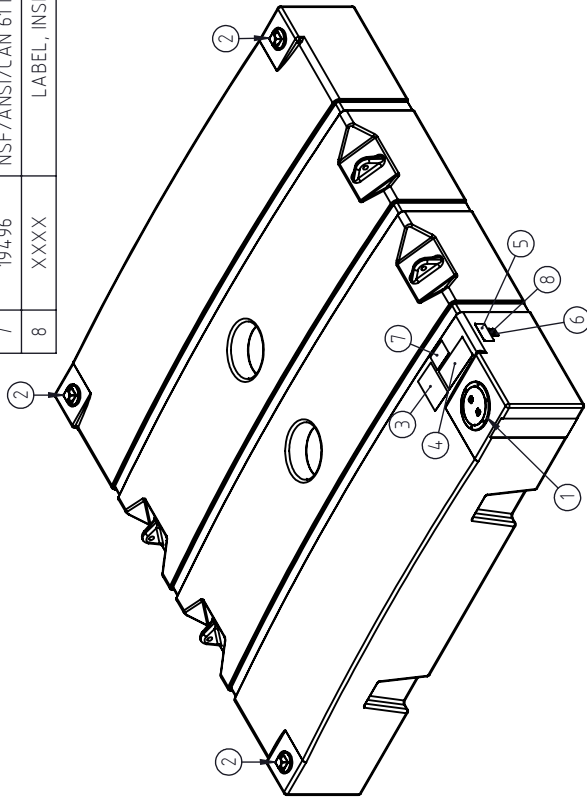

REV.	DESCRIPTION	BY	DATE	CCN
	ALL DIMENSIONS ARE IN DECIMAL INCHES. TOLERANCES UNLESS OTHERWISE SPECIFIED			
	POLYETHYLENE			
	METAL			
	DECIMAL ± .125" FRACTION ± 1/4" ANGLE ± 1°			
	±1% @ 68°F			
	THIRD ANGLE PROJECTION ANSI 14.5M			

DRAWN / DATE	MATERIAL :
SAS 9/19/2023	LLDPE
APPRD. / DATE	
BES 11/16/2023	
SHOT WEIGHT:	248.00 LBS.
SHIPPING WEIGHT:	250.00 LBS.
FINISH:	



**Den Hartog INDUSTRIES, INC.**  
 Ace Roto-Mold • Injection Molding • Blow Molding • Sowjoy  
 4010 HOSPERS DRIVE S. BOX 425, HOSPERS, IOWA 51238-0425

DESCRIPTION
LP, 500 GAL HOLDING TANK

SCALE	PART NO.
N.S.	LP0500-HT