

**STANDARD CONFIGURATION**

ITEM NO.	DESCRIPTION	QTY.
1	BASE, 2.1 PUMP SHELF	1
2	LID, 2.1 PUMP SHELF	1
3	PLEXIGLASS WINDOW 9-3/4" X 13-3/4" X 1/8"	1
4	NO. 6 X 1/2" FLAT HEAD SCREW	8
5	LID PROP, Ø1/2" X 19-3/8", FIBERGLASS	1
6	1/4"-20 X 3/4" SCREW, FLAT HEAD, SS	4
7	LG. PUMP PLATE, 16" X 8" X 1/2"	1
8	HINGE ROD, Ø1/4" X 8-3/4", ALUM	2
9	1/4" AXLE NUT (CAP NUT), ALUM.	4
10	2" FNPT SPIN WELD FITTING, PE	2
11	2" THREADED PLUG, PE	2
12	ANGLE BRACKETS, ALUM, 1-1/2" X 1-1/2"	4
13	WASHER	4
14	1/4"-20 X 5/8" PHILLIPS PAN HEAD, SS	4
15	1" MPT PLUG, PE, BLACK	4
16	1" FNPT SPIN WELD FITTING, PE, BLACK	4
17	1/4" X 1" FENDER WASHER, ZINC	1
18	1/4"-20 X 1" PHILLIPS ROUND HEAD, SS	1
19	1/4" NPT THREADED HEX SOCKET PLUG, HDPE, BLACK	2
20	1/4" FNPT FLUSH SPIN WELD FITTING, PE, BLACK	2
21	MOLD-IN GRAPHIC	1

PCS 2.1	PART NUMBERS	
	BLUE	NATURAL
STANDARD	253-30834	253-30835
W/ DIVIDER*	253-29867	253-29870

\*SEE OPTIONAL FEATURES, SHEET 2

- NOTES:**
- MATERIAL:** LLDPE 8460 SERIES (EXXON MOBILE), **COLOR:** BLUE, **FINISH:** SHOT PEEN
  - PART WEIGHT:** APPROX. 26 LBS.

**PROPRIETARY AND CONFIDENTIAL**  
 THE INFORMATION CONTAINED IN THIS DRAWING IS THE SOLE PROPERTY OF PEABODY ENGINEERING. ANY REPRODUCTION IN PART OR AS A WHOLE WITHOUT THE WRITTEN PERMISSION OF PEABODY ENGINEERING IS PROHIBITED.

UNLESS OTHERWISE SPECIFIED:		NAME	DATE	
DIMENSIONS ARE IN INCHES TOLERANCES: FRACTIONAL ± 1/8" ONE PLACE DECIMAL ± .25" TWO PLACE DECIMAL ± .125" THREE PLACE DECIMAL ± .063"		DRAWN	RFR 12/30/13	
TANK MATERIAL:		CHECKED		PROJECT: 2.1 PCS PUMP SHELF
INNER TANK S/N:		ENG APPR.		CUSTOMER: PEABODY STANDARD
OUTER TANK S/N:		MFG APPR.		SITE/LOCATION:
CUSTOMER PO#		Q.A.		DRAWING#: SEE TABLE
DO NOT SCALE DRAWING		COMMENTS:		SIZE B DESC. PCS 2.1 STANDARD REV. H
				SCALE: 1:10 SHEET 1 OF 3

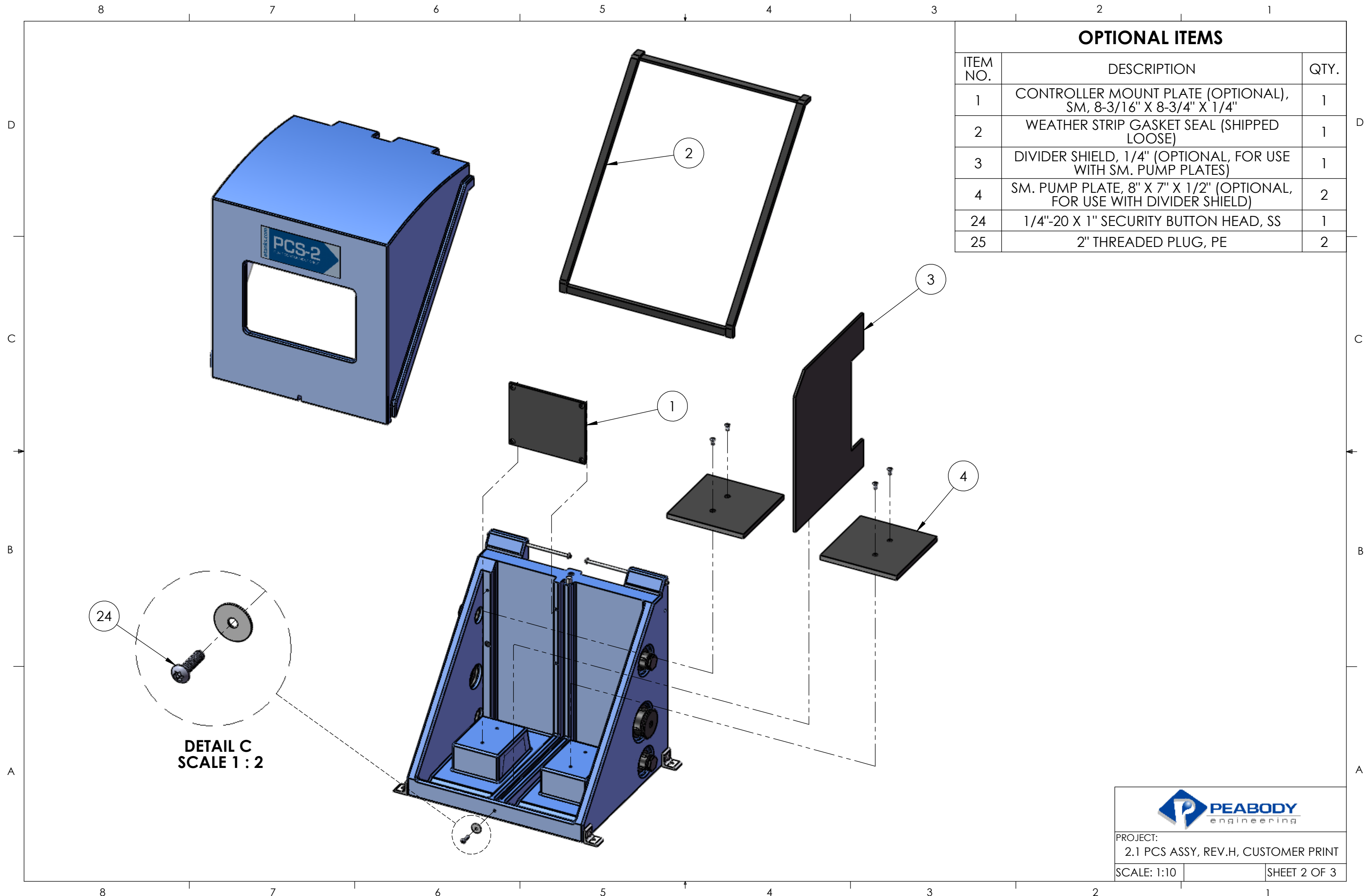

**OPTIONAL ITEMS**

ITEM NO.	DESCRIPTION	QTY.
1	CONTROLLER MOUNT PLATE (OPTIONAL), SM, 8-3/16" X 8-3/4" X 1/4"	1
2	WEATHER STRIP GASKET SEAL (SHIPPED LOOSE)	1
3	DIVIDER SHIELD, 1/4" (OPTIONAL, FOR USE WITH SM. PUMP PLATES)	1
4	SM. PUMP PLATE, 8" X 7" X 1/2" (OPTIONAL, FOR USE WITH DIVIDER SHIELD)	2
24	1/4"-20 X 1" SECURITY BUTTON HEAD, SS	1
25	2" THREADED PLUG, PE	2

**DETAIL C  
SCALE 1 : 2**



PROJECT:  
2.1 PCS ASSY, REV.H, CUSTOMER PRINT

SCALE: 1:10 | SHEET 2 OF 3

8 7 6 5 4 3 2 1

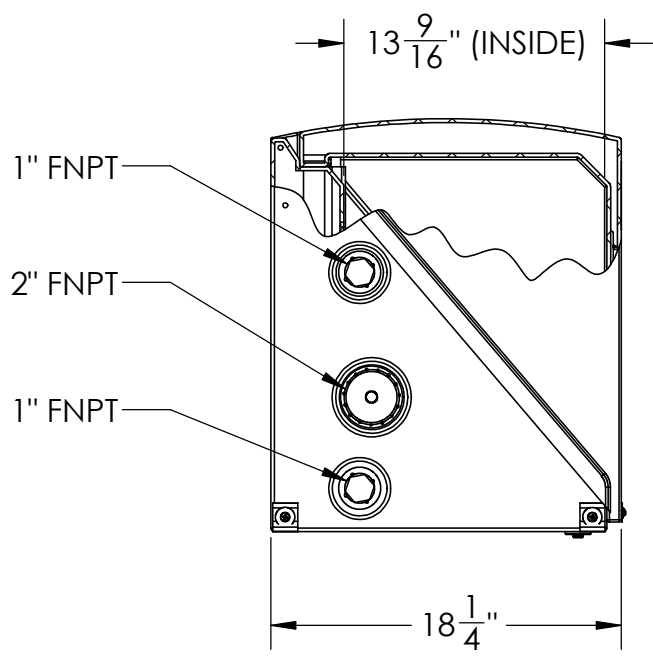

**LEFT VIEW  
(CLOSED, STANDARD  
CONFIGURATION)**

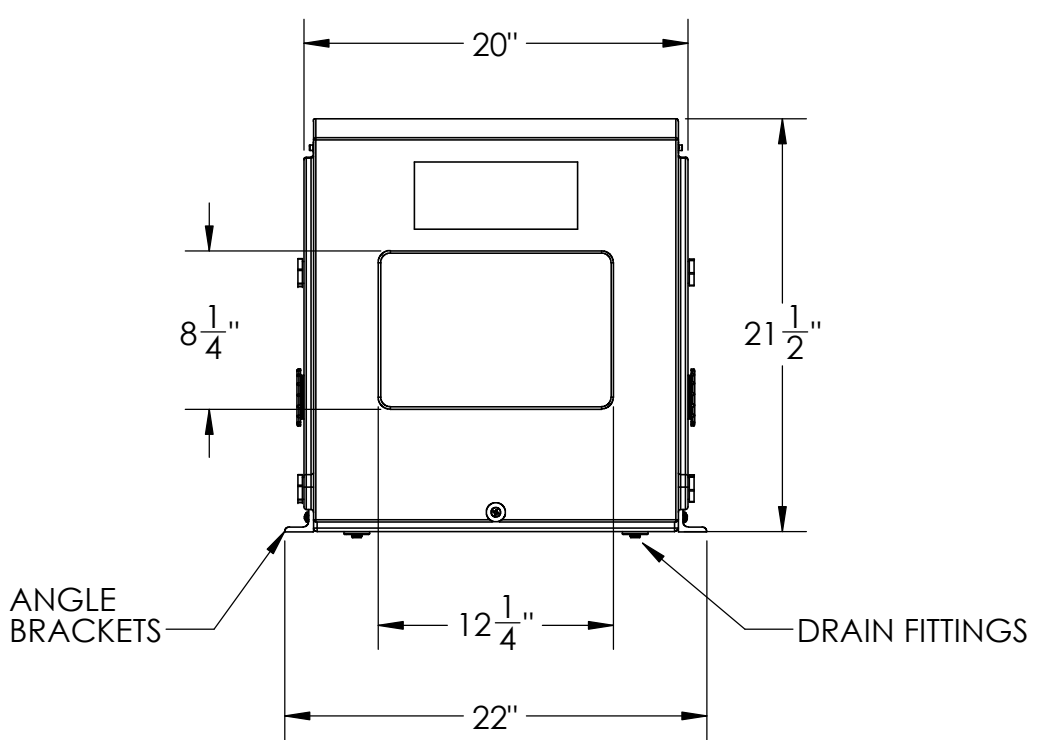

**FRONT VIEW  
(CLOSED, STANDARD  
CONFIGURATION)**

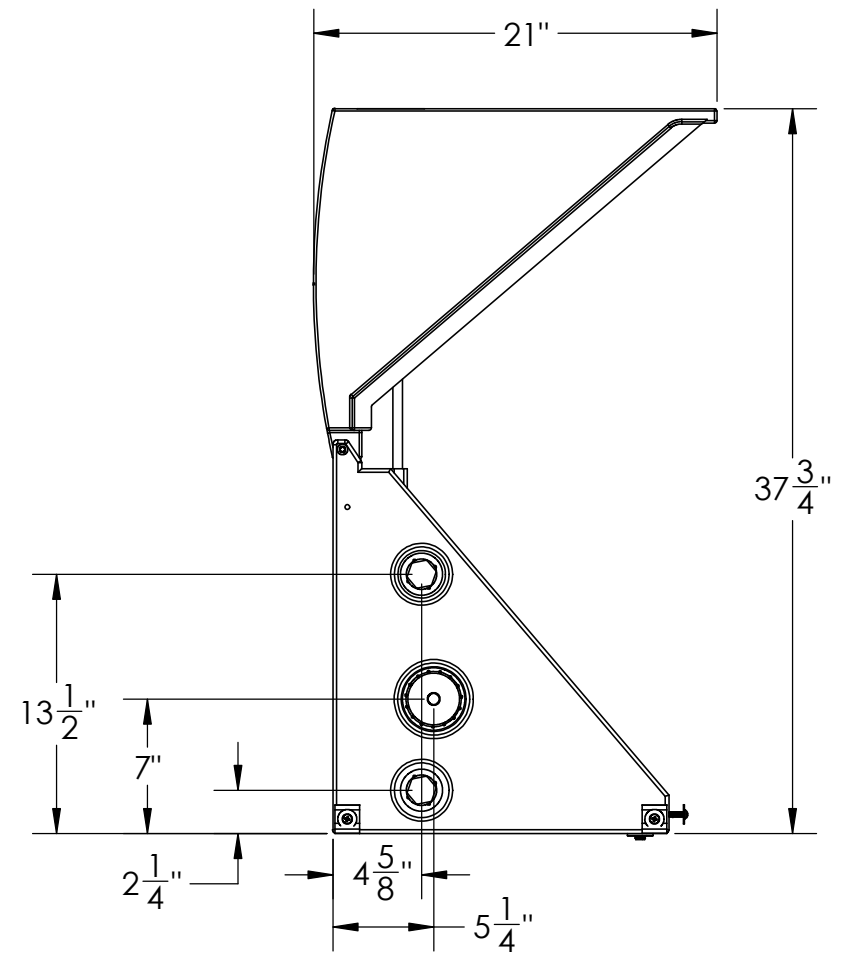
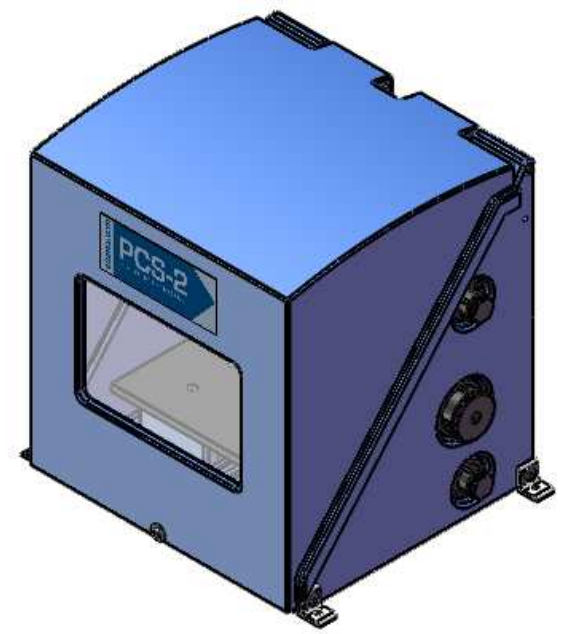

**LEFT VIEW  
(OPENED, STANDARD  
CONFIGURATION)**

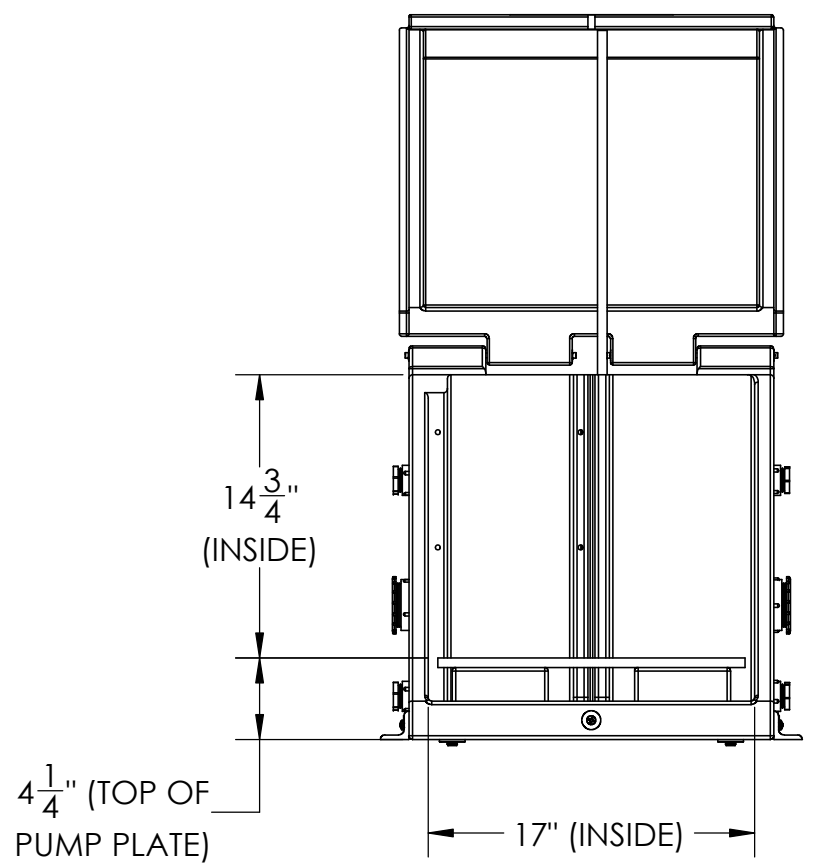

**FRONT VIEW  
(OPENED, STANDARD  
CONFIGURATION)**

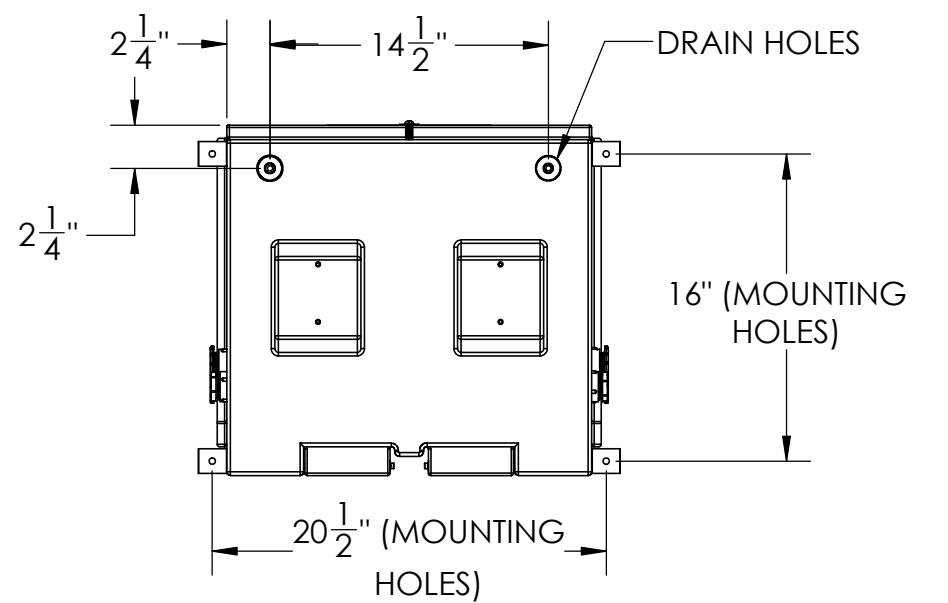

**BOTTOM VIEW  
(CLOSED, STANDARD  
CONFIGURATION)**



PROJECT:  
2.1 PCS ASSY, REV.H, CUSTOMER PRINT

SCALE: 1:10

SHEET 3 OF 3

8 7 6 5 4 3 2 1

D  
C  
B  
A

D  
C  
B  
A