

304 Stainless Steel Push-Fit Connectors

Series: SSPF
Installation Instructions



SSPF Series Stainless Steel Push Fit fittings are versatile and reliable, designed for use with copper, CPVC, PEX, PE-RT & HDPE piping in plumbing and hydronic heating systems. Approved for behind-the-wall installations with or without access panels, and underground applications (with proper wrapping to prevent corrosion). These fittings are ideal for potable and non-potable water use. They eliminate the need for soldering, crimping, or solvent welding, making them perfect for repairs in wet, hazardous, or hard-to-reach locations where open flames pose a fire risk. The fittings come complete with stiffeners for PEX, PE-RT & HDPE piping, which can be removed for copper installations. Additionally, the fittings are reusable and easily disassembled using the plastic Disconnect Clip.

Pressure & Temperature Ratings

- Maximum pressure rating: 300 PSI (2068.43 kPa)
- Maximum temperature rating: 200°F (93°C)



Before installing a push-fit fitting check that the fitting and pipe or tube are clean, in good condition and are free of damage, burrs and foreign debris.

Tools Required: Marker, Measuring Tape, Plastic Pipe Cutter for PEX, PE-RT, HDPE & CPVC, Rotary Cutter for Copper.

Installation Instructions

Connecting a Push-fit Fitting

1. Cut the pipe so that the ends are square. Check that there are no burrs or damage to the cut end, to ensure the pipe does not damage the O-ring seal, to ensure a water-tight connection. Use a cutting tool appropriate for the type of pipe or tube.

2. Use a marker to mark the proper depth of insertion on the outside of the pipe (see table). This mark is used as a visual guide to ensure that the tubing is inserted all the way to the tubing stop. Failure to insert the tubing against the stop will produce an insecure joint.

Suggested Pipe Insertion Depth		
Fitting Size	Pipe Insertion Depth	
	in	mm
1/2"	1	25.4
3/4"	1-1/4	31.8
1"	1-5/16	33.3

Copper pipe installation

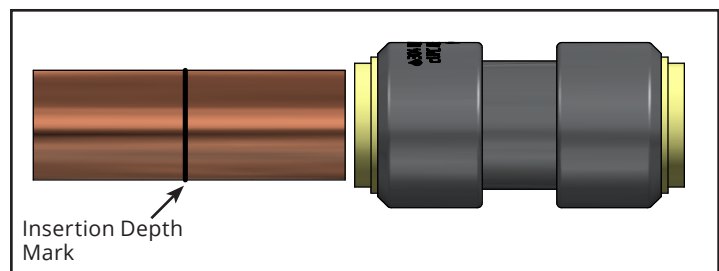

PEX pipe installation

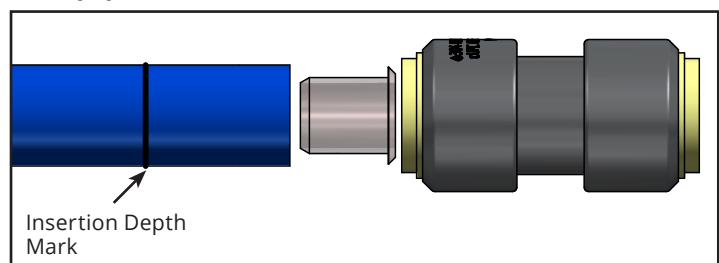

304 Stainless Steel Push-Fit Connectors

Series: SSPF
Installation Instructions



3. Insert the tubing through the release collar, stainless steel gripper ring, and O-ring. Push the pipe firmly with a slight twisting motion until it contacts the tube stop. Confirm that the depth mark is flush with the edge of the release collar.

NOTE:

A pipe stiffener must be inserted into all PEX, PE-RT, & HDPE pipe before connecting the joint to reduce the chance of leaks by giving more rigidity to the length of the pipe within the fitting.

IMPORTANT! The stiffener required for PEX, PE-RT, & HDPE piping installations adds approximately 1/16" to the pipe length. This must be taken into consideration when making the insertion depth marking on PEX, PE-RT or HDPE pipe.

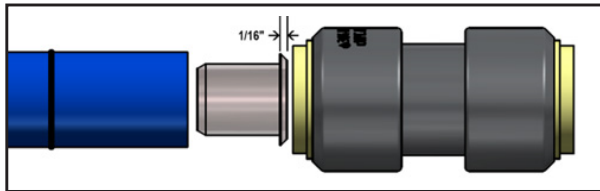

Disconnecting a Push-fit Fitting

Tools Required: Push-fit Disconnect Clip

1. Place the Disconnect Clip around the tubing with the recessed face against the release collar.

2. Push and hold the Disconnect Clip against the release collar and pull the tubing with a twisting motion to release.

3. Check the fitting and tubing end for any damage. The cut end should be free of damage, burrs and foreign debris. If the pipe or tube end is damaged or marked, then cut and use a new section.

Disconnect Clip (PF-DC Series)

Stiffener (PF-S Series)



Copper pipe inserted

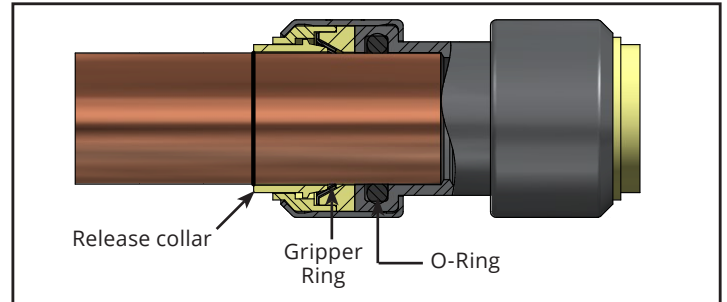

PEX pipe inserted

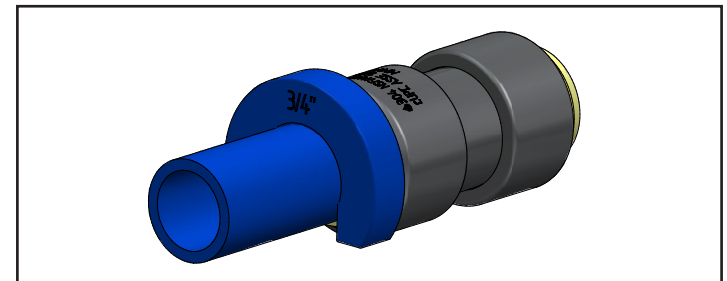
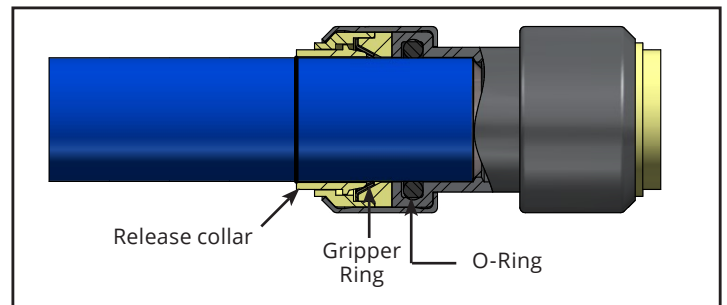

Push and hold disconnect clip against release collar

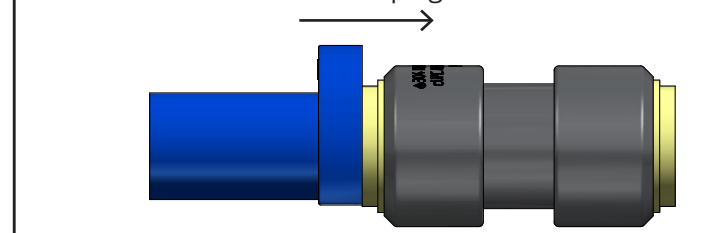

Pull tube out of fitting

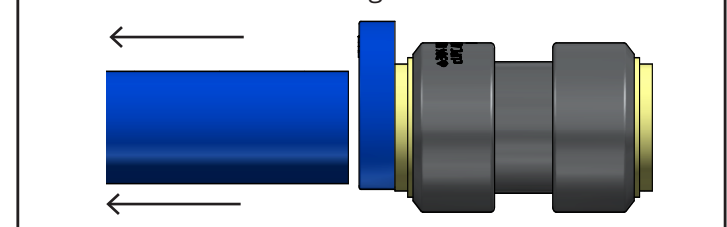

304 Stainless Steel Push-Fit Connectors

Series: SSPP
Installation Instructions

BOSHART
INDUSTRIES

Special Installation Requirements

Burial

Due care should be given to any environmental factors that may have a detrimental effect on the life expectancy of the fittings and pipe. The installation of a push-fit connector in applications that will require the burial of the fitting must comply with all local plumbing code requirements. This may not be suitable for areas where the soil is or could become contaminated. Ensure soil used for back filling is free of rocks, debris or any sharp objects that may cause damage to the pipe or fitting through impact or abrasion. Fittings must be wrapped with silicone tape.

Silicone Burial Wrap

Always follow the guidelines for minimum bury depth in your area. These instructions are meant to be used as a guide, always follow the manufacturer's instructions for applying the silicone pipe wrap to the fitting. Ensure pipe is inserted to proper depth when making a connection. Leave the protective film in place while measuring the amount of tape needed to completely wrap the fitting. Ensure the tape extends a minimum of 1-1/2" past the end of the fitting onto the pipe at both ends. Remove protective film and completely cover the fitting. Work around the fitting overlapping the tape 1/2 the width of the tape, peeling away the protective film to enable the tape to bond to itself. Continue wrapping until the entire fitting is covered. The tape will bond to itself within a few minutes and after a few hours will cement itself forming a water and air tight seal. Bonding time may vary from one brand of tape to the next.

Behind-The-Wall

It is highly recommended to verify with the applicable National and Local plumbing and or building codes for your specific applications. Consulting with the AHJ (Authority Having Jurisdiction) over the project, the AHJ must follow the applicable plumbing and building codes, however they have the ability to reject a product or material that meets the codes for a specific project or applications. It is highly recommended to pressure test the system prior to sealing up the wall.

IMPORTANT! In behind-the-wall applications, the piping must be protected from accidental puncture from nails or screws with metal nail plates.

Distance Between Fittings

Allow at least 1" of space between fittings for removal purposes.

Threaded Connectors

To make a proper seal with Stainless Steel Push Fit Fittings, we highly recommend using both Polytetrafluoroethylene (PTFE) thread sealing tape and a high quality thread sealing compound.

Fittings in Concrete

Avoid joints within a slab. Use a continuous length of PEX pipe instead and ensure no leaks before pouring concrete.

Galvanized Pipe

It is not recommended to thread push fit fittings onto galvanized pipe. Joining dissimilar metals should be avoided whenever possible.

Grounding on Copper Pipe

When connecting to a copper piping system, a copper jumper cable should be installed to ensure proper grounding.

Soldering

When soldering is required near a push-fit fitting, make all solder joints first, then make the push-fit connections after the solder joint has cooled. High temperatures caused by flame are not recommended when working close to push-fit fittings.

Fitting Reuse

Repeated connection is not ideal for push-fit fittings, they are intended to be permanent and not designed for repeated use after initial install. In the case that a fitting is installed incorrectly, given that proper care is taken it can be removed. Ensure the initial pipe and new pipe are clean and free from scratches or burrs. Remember to mark the insertion depth. It is recommended that a reinstalled connection be pressure tested and inspected by the installer to verify that there are no leaks.

Repair Couplings

Push fit repair couplings can be used to repair either copper or CPVC pipe. A maximum of 2 inches of damaged pipe can be removed, making sure it is cut as square as possible and free of scratches or foreign debris. After measuring and marking proper insertion depth, make the connection by sliding the "SLIP" end of the fitting onto the pipe as far as it will go. Use the Disconnect Clip to disengage the gripper ring teeth on the slip end allowing you to slide the coupling back over the adjoining piece of pipe until you align it with the insertion depth mark.

304 Stainless Steel Push-Fit Connectors

Series: SSPF

Installation Instructions



Outdoor Fixtures

Generally, SSPF Push-Fit fittings are used for indoor installations. They can also be used to plumb fixtures outside. They are resistant to damage from UV light and do not require special care to protect from exposure to the outdoors. The pipe must not be exposed to freezing temperatures, and ensure the outdoor pipes and fittings are drained for the winter or are sufficiently insulated.

Leaking After Installation

Review the installation instructions to ensure all the pipe preparation and installation steps have been followed. Some common causes for a leaking Push-Fit fitting connection are:

- Improper pipe preparation, failure to make a square clean cut and deburr the pipe prior to installation
- Failure to insert the pipe in axial alignment with the fitting can damage the O-ring
- Failure to insert the pipe all the way into the pipe stop, this is why making the insertion depth is important to provide a visual means to inspect proper insertion
- The pipe has foreign debris and/or scratches on the outside which prevents the O-ring from making a water-tight seal

For more information on installation, adjustment, repair & operation, visit Boshart Knowledge Base at

[SUPPORT.BOSHART.COM](https://support.boshart.com)

